

Instrumentation Manifolds: Traditional, C13ST Series

For DPharp EJX & EJA-E Differential Pressure and Pressure Transmitters



Introduction

Introduction

The partnership of Yokogawa and AS-Schneider creates a real added value to our customers.

Yokogawa Electric Corporation with its headquarters in Japan is one of the World's Leading Manufacturers and Engineering Service Provider in the fields of Automation, Measurement, and Control.

The AS-Schneider Group with its headquarters in Germany is one of the World's Leading Manufacturers of Instrumentation Valves and Manifolds. AS-Schneider offers a large variety of Valves and Manifolds as well as numerous accessories needed for the instrumentation installations globally.

In this catalogue you will find C13ST Manifolds for Yokogawa's DPharp EJX Series and EJA Series Transmitters for Differential Pressure, Gauge and Absolute Pressure Applications and the relevant Installation Accessories.

Continuous product development may from time to time necessitate changes in the details contained in this catalogue. AS-Schneider and Yokogawa reserve the right to make such changes at their discretion and without prior notice.

All dimensions shown in this catalogue are approximate and subject to change.



Body Material Options

Material Group	AS Material Designation	Material No.	Short Name	Equivalent UNS-No.	Material Grade	
					acc. to ASTM	acc. to JIS
Austenitic Stainless Steel	316 quadruple certified*	1.4401	X5CrNiMo17-12-2	S31600	316	SUS316
		1.4404	X2CrNiMo17-12-2	S31603	316L	SUS316L
Austenitic-Ferritic Stainless Steel	Duplex	1.4462	X2CrNiMoN22-5-3	S31803	F51	SUS329J3L
	Superduplex	1.4410	X2CrNiMoN25.7.4	S32750	F53	
Nickel Based Alloys	Alloy 400	2.4360	NiCu30Fe	N04400		NW4400
	Alloy C-276	2.4819	NiMo 16 Cr 15 W	N10276		NW0276
	Alloy 625	2.4856	NiCr22Mo9Nb	N06625		NCF 625

* Quadruple certified means 316 / 316L / 1.4401 / 1.4404

Standard Features

- Bore Size 5 mm
- Manifolds are not supplied with plugs unless specified.
- Anti-Tamper Head Unit Options see Page 6.

Needle Seal:

PTFE and Graphite Packings are available for all valve types. When Graphite Packing is selected, material of Flange Seal and Tape for Tapered Pipe Threads is also Graphite (when applicable).

Sour Gas Service:

Wetted Parts according to a.m. material list are supplied as standard according to NACE MR0175/MR0103 and ISO 15156 (latest issue).

Pressure Test:

A Shell Test and a Seat Leakage Test are performed at 1.5 times the max. allowable (working) pressure acc. to EN 12266-1 - P10, P11 and P12 respectively MSS-SP61 at every Standard Manifold → 100% Pressure Tested!

Optional Features

Fugitive Emission Application:

For Fugitive Emission Applications AS-Schneider is providing ISO 15848 and TA-Luft Solutions. For more details see Pages 5.

Oxygen Service:

An option with Reinforced PTFE Packing is offered duly cleaned and lubricated for Oxygen Service:

Pressure-Temperature Rating:

Max. 420 bar (6,092 psi) @ 60°C (140°F)
Max. 200°C (392°F) @ 90 bar (1,305 psi)

Not every Valve Type is available for Oxygen Service!

Stainless Steel 316 Bolts:

Manifold mounting bolts are supplied in Carbon Steel as Standard. SS316 Bolts are available as an option.

Stainless Steel 660 D Bolts:

When NACE Compliant Bolting is required please use Bolting Option N2 or N4 → ASTM A453 Gr. 660 Class D.

If you don't find your options in this catalogue please contact Yokogawa.

Certification:

Inspection Certificate 3.1 acc. to EN 10 204 for valve body material and pressure test available as standard.

The manifolds can be provided upon request with a

- CRN Certificate
- EAC Certificate – Manifolds are marked with EAC

PMI Test on request. Test points are one each on body and valve bonnet. A combined certificate for each order is provided listing the chemical analysis for each manifold.

Graphite packed manifolds are Fire Safe Tested and Certified as standard.

Pressure-Temperature Rating

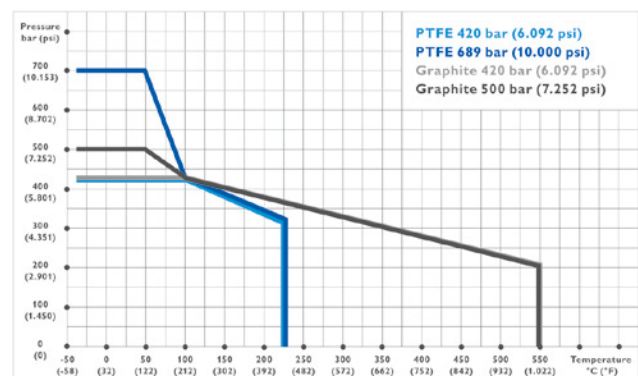

Low-temperature Limits:

- Standard Valves with PTFE and Graphite Packing: -40°C (-40°F)
- Valves with PTFE Packing and Arctic Operations Option, Option Code L []: -55°C (-67°F)



Packing adjustment may be required during the service life of the valves.



Valves that have not been cycled for a period of time may have a higher initial actuation torque.

Standard Valve Head Units

Standard Bonnet Design

T Handle

Ergonomic Handle Design.
Operating options are Anti-Tamper features or a Stainless Steel Handwheel.

Valve Stem

Stem with cold rolled threads for high strength and smooth operation.

Needle Seal

Standard: PTFE or Graphite Packing

Needle

Non-rotating Needle for smooth operation and minimum wear of sealing elements.

Back Seat

Metal to Metal secondary needle seal and therefore the needle is anti-blowout / non-removable – For your safety.

Needle Tip

Choices of Needle Tip Materials, same as body material.

Valve Seat

Metal seated (integral type).

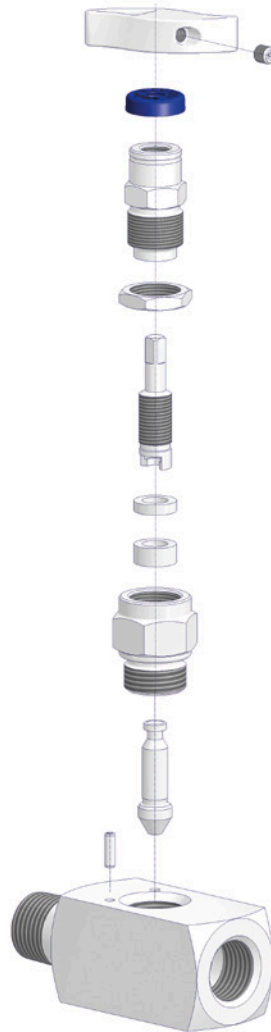

Color Coded Dust Cap

For operating thread protection:

Isolate	BLUE
Vent/Test	RED
Equalize	GREEN

Color Coded Options

Following options are also color coded below dust cap:

Oxygen Service	
Graphite Packing	
TA-Luft Option	

Lock Pin

Eliminates unauthorized removal of the bonnet assembly.

Bonnet

Metal to Metal Seal to Valve Body.

Traceability of Materials

All Manifolds have material traceability. A unique code is stamped on all valve bodies linking them with their material and chemical analysis certificates.

Flow Data

Needle Valves Standard Head Unit – Bore Size 5 mm

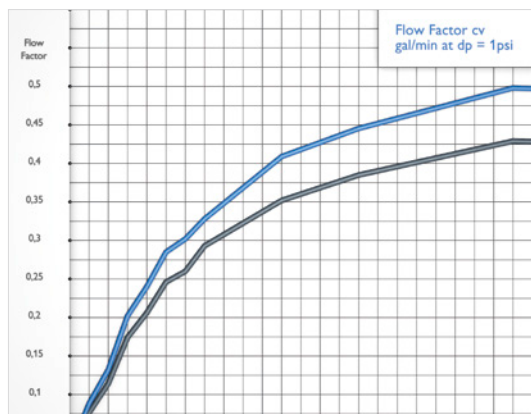

Materials of Construction

Components	Stainless Steel	Exotic Alloys				
	Material / Material No.					
Body						
Bonnet	SS 316 / 316L	Alloy 400	Alloy C-276	Duplex S31803	Super Duplex S32750	Alloy 625
Needle						
Pipe Plug						
Valve Stem	316 / 316L					
Gland	316					
Packing	PTFE or Graphite					
Stem Nut	316					
Lock Nut	316					
Set Screw	316					
T Handle	316					
Lock Pin	A4 (316)					

Wetted components listed in **bold**.

Standard Needle Valves

Screwed Bonnet – Stem Seal: Packing

Features

- Lock Pin – Eliminates unauthorized removal of the bonnet
- Standard Packing in PTFE and Graphite available
- Max. allowable (Working) Pressures (PS):
 - Block & Bleed Manifolds for In-Line Mount Transmitters
 - 689 bar (10,000 psi) – For PTFE Packing
 - 500 bar (7,252 psi) – For Graphite Packing
 - Direct Mount Manifolds acc. to IEC 61518
 - 420 bar (6,092 psi)
 - Direct Mount Manifolds with Flange Connection for High Pressure Type MWP 500 bar (7,252 psi)

Standard Features applicable for all illustrated valve types:

- Integral Valve Seat – Metal to Metal Seated
- Non-rotating Needle
- External Stem Thread – Packing below stem threads. Stem Threads are protected from process media (non-wetted), helps to prevent stems from galling.
- Stem with cold rolled threads
- Blow-out proof Needle
- Back Seat – Metal to metal secondary needle Seal
- Color Coded Dust Cap for operating thread protection
- Anti-Tamper Valve Head Options available
- All non-wetted parts in 316 stainless steel

Standard Design
420 bar (6,092 psi)

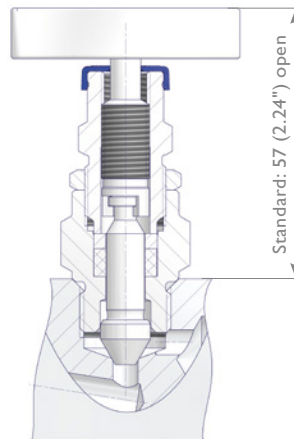

High Pressure Design
689 bar (10,000 psi) and
500 bar (7,252 psi)

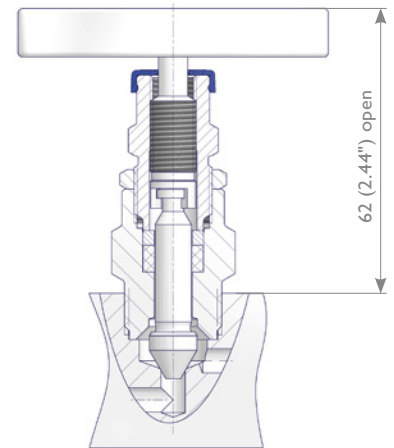

Body-to-Bonnet Seal is below the threads eliminating process fluid corrosion.

Needle Valves according ASME B31.1 (Power Piping)

Screwed Bonnet – Stem Seal: Graphite Packing

Meet the requirements of ASME B31.1 (Power Piping).

Max. allowable (Working) Pressure (PS): 500 bar (7,252 psi)

A Locking Plate eliminates an unauthorized removal of the bonnet.

→ Standard Features see above table with a grey colored background.

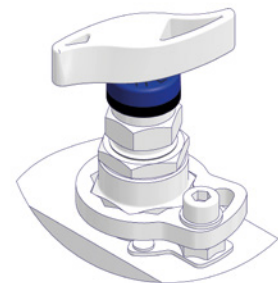

Option Code P[]

Needle Valves acc. to ISO 15848

Screwed Bonnet – Type 1 O-Ring Stem Seal + Graphite Packing
Type 3 PTFE Packing

Features

- Max. allowable (Working) Pressure (PS): 420 bar (6,092 psi)
- Lock Pin – Eliminates unauthorized removal of the bonnet
- FKM O-Ring Needle Seal – RGD (Rapid Gas Decompression) resistant
- PTFE or Graphite Packing
- Types also comply with the requirements of TA-Luft 2002

→ Standard Features see above table with a grey colored background.

ISO FE Performance Data

ISO FE Type 1:	Class B 1,500 cycles / -29°C to 200°C
Class A 1,500 cycles / -29°C to 40°C	(-20°F to 392°F)
(-20°F to 104°F)	ISO FE Type 3:
Class A 500 cycles / -29°C to 200°C	Class B 1,500 cycles / -29°C to 200°C
(-20°F to 392°F)	(-20°F to 392°F)

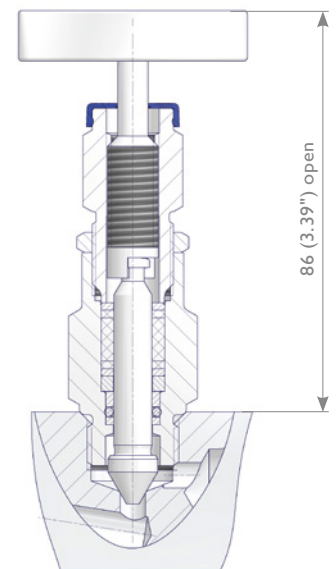

Option Code D[] or E[]

Valve Head Unit Options

Needle Valves according to TA-Luft

The German TA-Luft (Technical Guidelines for Air Pollution Control) gives guidelines for compliance with permissible leak rates. The TA-Luft requirement is considered to be complied with if bellows sealed head units with a safety packing or similar sealing systems are used; whereby the equivalence in the verification system must be confirmed in accordance with VDI 2440.

Features

- Max. allowable (Working) Pressure (PS): 420 bar (6,092 psi)
- Cup & Cone Packing (Reinforced PTFE) – TA-Luft Option
- Lock Pin – Eliminates unauthorized removal of the bonnet

→ Standard Features see table with the grey colored background on Page 5.

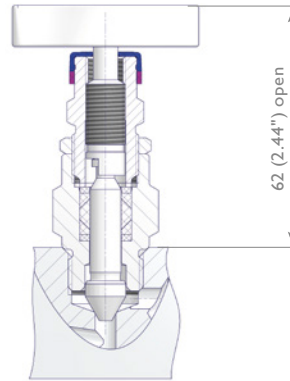

Option Code W[]

Anti-Tamper Valve Head Unit Options

Two types of Anti-Tamper Valve Head Units are offered, both types are lockable with a padlock (not supplied with manifold). Please refer to Page 19 for detail of Ordering Information.

Standard Anti-Tamper Head Unit

The valves are operated with a special Anti-Tamper Key (AT-Key), which fits exactly in the key guide. The valve can therefore only be operated with the AT-Key. In addition to this safety function, installing a padlock prevents the AT-Key being inserted into the key guide. Operating the valve is therefore no longer possible which protects your equipment against unauthorized opening and closing of the valve head units. The valve can be locked reliably in every position required.

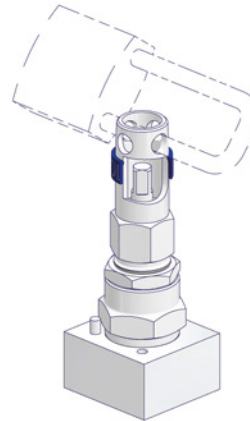

Option Code R[] or T[]



Part Number C13SA-ATKES

Stainless Steel Handwheel and 'Locking Plate' Design

The valves can be ordered optional with Stainless Steel Handwheel (Option Code H) and also with an additional fitted locking plate (Option Code L). This design allows minimum handle movements and is ideal as protection against unauthorised closing of the valve.

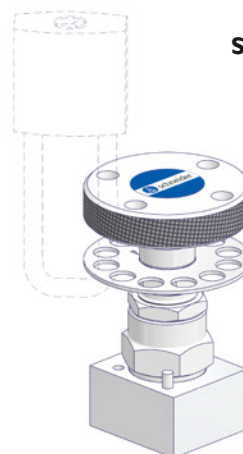

Option Code L[]

Stainless Steel Handwheel

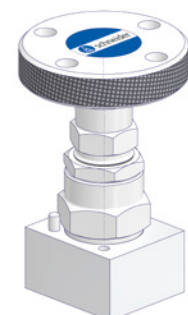

Option Code H[]

Flange Connections

Flange Connection according to IEC 61518

According to IEC 61518 the manifold-transmitter interface is applicable for a max. allowable (Working) Pressure (PS) of 413 bar*³ (6,000 psi) and a max. allowable Temperature (TS) of 120°C (248°F) for liquids, gas or vapors. The max. allowable Temperature (TS) of 120°C (248°F) is considering the requirement that manifolds and transmitters need to be protected against heating by hot media. This can be achieved by using adequate hook-ups or by instrument impulse lines with sufficient length. However the Manifolds are suitable for temperatures up to 550°C (1,022°F), PTFE up to 232°C (450°F), Graphite up to 550°C (1,022°F).

Manifold Connection acc. to IEC 61518 Type B

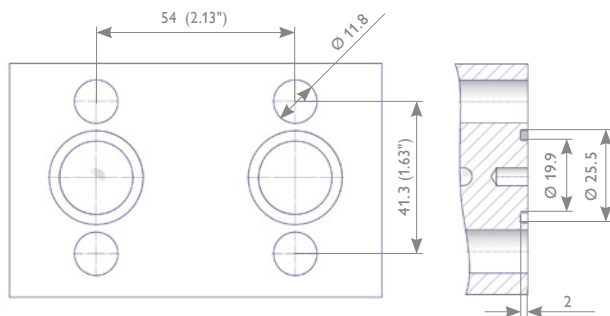

Process Connection of H-Style Manifolds or Transmitter Connection acc. to IEC 61518

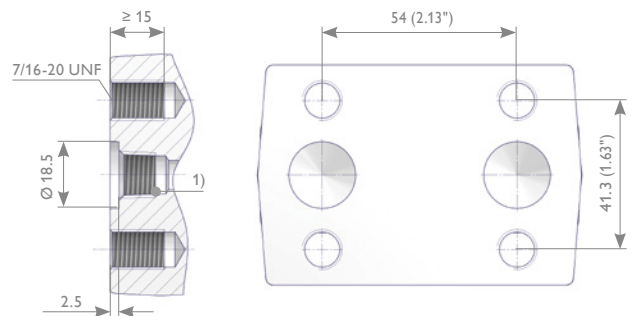

1) Threaded option for transmitters – Pipe Plug, Vent Valve or Compression Fitting can be installed.

Flange Connection for High Pressure Type MWP 500 bar*⁴

A Yokogawa proprietary flange connection for High Pressure Transmitters is also available optionally. Not available for H-Style Manifolds with Graphite Packing.

Manifold Connection – MCHP-Style

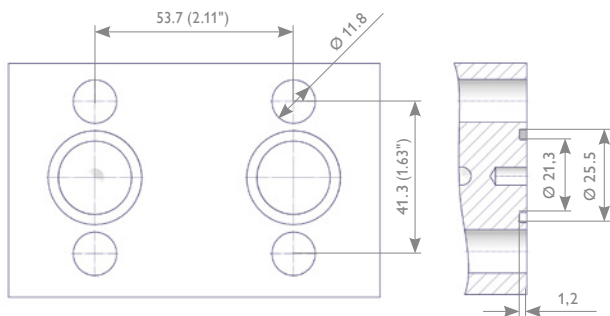

Transmitter Connection

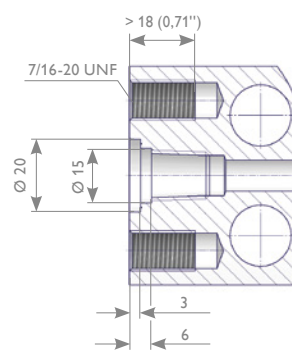

Process Connection of H-Style Manifolds for High Pressure Type – PCHP-Style

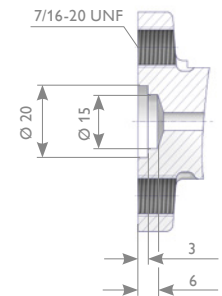

	Connection at the manifold acc. to IEC 61518* ¹ I* ³ Type B		Flange Connection for High Pressure Type* ⁴
Max. allowable (Working) Pressure (PS) in bar (psi)	413 (6,000)* ³		500 (7,252)* ⁴
Temperature Range in °C (°F)	-10 to +80 (14 to 176)	-40 to +120 (-40 to 248)	-40 to +120 (-40 to 248)
Seal Ring* ²	Flat Ring 25.4 x 20 x 2.7 Material: PTFE	Flat Ring 25.4 x 19.9 x 2.9 Material: Graphite	Flat Ring 25.2 x 21.6 x 2 Material: Reinforced PTFE
Min. Thread Engagement in mm	9		9

*¹ IEC 61518 I Mating dimensions between pressure measuring instruments and flanged-on shut-off devices up to 413 bar (6,000 psi).

*² Materials and temperature limits for the flat rings and the O-Rings are for reference only. It is the responsibility of the user to ensure compatibility between the selected gasket ring material and the process requirements, such as pressure, temperature, and chemical compatibility.

*³ IEC 61518 is stating 413 bar (6,000 psi), AS-Schneider however confirms 420 bar (6,092 psi).

*⁴ For Transmitter Model EJ □ 440 and EJ □ 130 with MWP ≥ 320 bar to ≤ 500 bar.

Connections

Manifold-to-Transmitter and Process Connector-to-Manifold Assembly

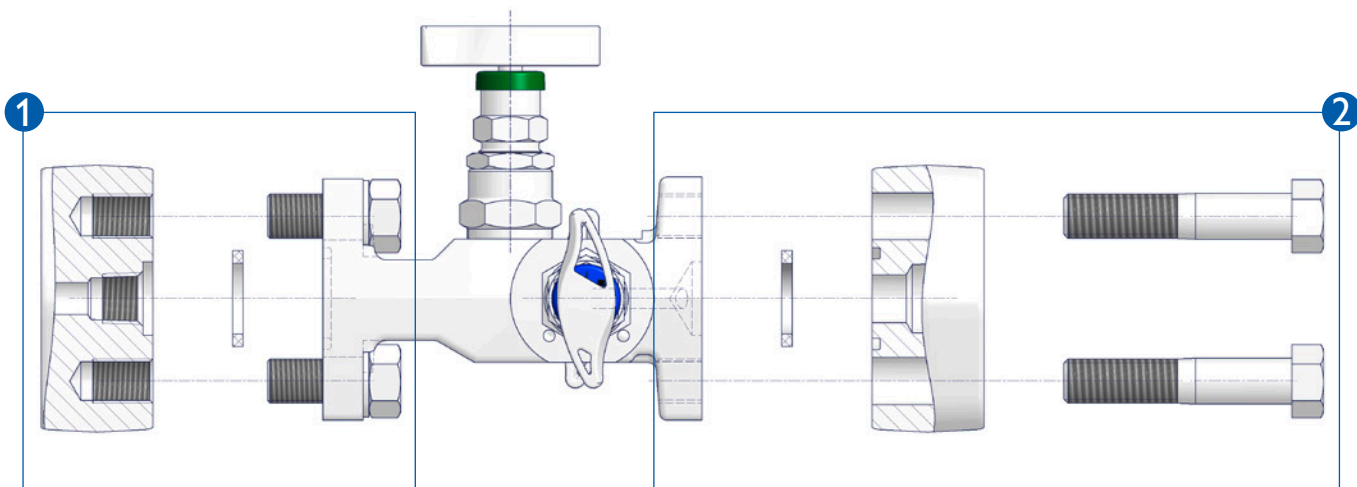

1 Direct Mount Manifolds are supplied as standard with Carbon Steel Bolts and PTFE Seal Rings* :

Wafer Style

2 Valve Manifolds: 2 Bolts, 1 Seal Ring
3 & 5 Valve Manifolds: 4 Bolts, 2 Seal Rings
Bolt Length 1.75"

T-Style and H-Style

2 Valve Manifolds: 4 Bolts, 4 Washers, 1 Seal Ring
3 & 5 Valve Manifolds: 4 Bolts, 4 Washers, 2 Seal Rings
Bolt Length 1"

* Reinforced PTFE Seal Rings for High Pressure Type Manifolds

2 Process Connector Option for H-Style Manifolds supplied as standard with Carbon Steel Bolts and PTFE Seal Rings:

2 Valve Manifolds: 2 Bolts, 1 Seal Ring
3 & 5 Valve Manifolds: 4 Bolts, 2 Seal Rings
Bolt Length 1.5"

Connection Size of Process Connector: 1/2 NPT Female

Process Connector-to-Manifold Assembly for High Pressure Type H-Style Manifolds **

3 Standard Process Connector for High Pressure Type pressure Transmitter is applicable for High Pressure Type H-Style Manifolds.

** Process Connector incl. bolts and flange seal for High Pressure Type are in the scope of supply with the Transmitter. Please make sure to order Transmitters with process connectors in case of H-Style.

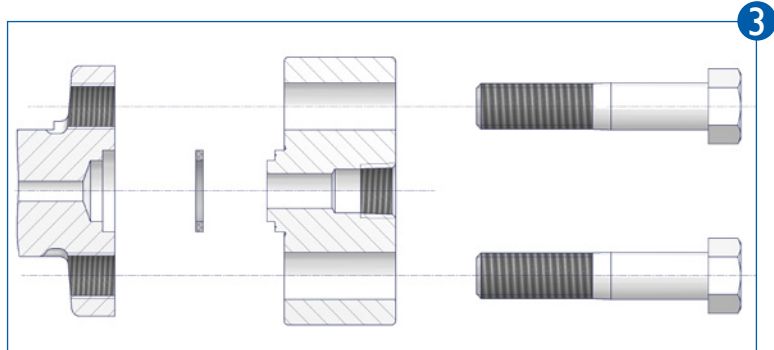

Hex Bolt Material used:

Carbon Steel: According to ASTM A449 – Type 1.

316 Stainless Steel: According to ASTM A193 B8M Class 2.

NACE Compliant Bolting: According to ASTM A453 Gr. 660 Class D.

Connection	Bolt Installation Torque Values	
	Initial Torque Value	Final Torque Value
IEC 61518		
Flange Connection for High Pressure Type	300 in.lb. (34 Nm)	646 in.lb. (73 Nm)

Bolt Installation Instructions:

1. Finger-tighten the bolts.
2. Torque the bolts to the initial torque value using a crossing pattern.
3. Torque the bolts to the final torque value using the same crossing pattern.

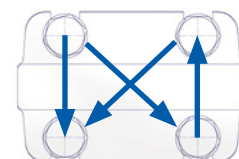

Block & Bleed Manifolds for In-Line Mount Absolute & Gauge Pressure Transmitters with Male or Female NPT Process Connection

Block & Bleed Manifolds (2 Valve Manifold)

Block & Bleed Manifolds are designed for In-Line Mount Absolute & Gauge Pressure Transmitters with Male or Female NPT Process Connection. The standard vent connection is 1/4 NPT female. Pipe Plugs are not supplied as standard. For Plugged Vent Ports (factory installed) and other Options see Pages 21 - 23 – Ordering Information.

Accessories like Mounting Brackets, Vent Valves, and Pipe Plugs etc. see also Pages 18 and 20.

Applicable for In-Line Mount DPharp Absolute & Gauge Pressure Transmitters

DPharp Pressure Transmitter Model		Application	Max. allowable (Working) Pressure (PS)		
			MPa	bar	psi
EJX Series	EJX510A	Absolute Pressure	50	500	7,200
	EJX610A		70	700	10,150
EJA Series	EJA510E		50	500	7,200
EJX Series	EJX530A	Gauge Pressure	50	500	7,200
	EJX630A		70	700	10,150
EJA Series	EJA530E		50	500	7,200

Block & Bleed Manifolds – Female Threaded Instrument Connection

C13ST-2G[]DT Type

1/2 NPT Female Process x 1/2 NPT Female Instrument

C13ST-2G[]ET Type

1/2 NPT Male Process x 1/2 NPT Female Instrument

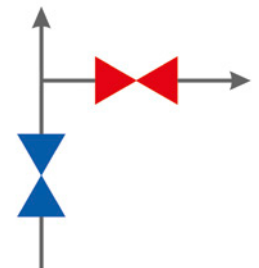
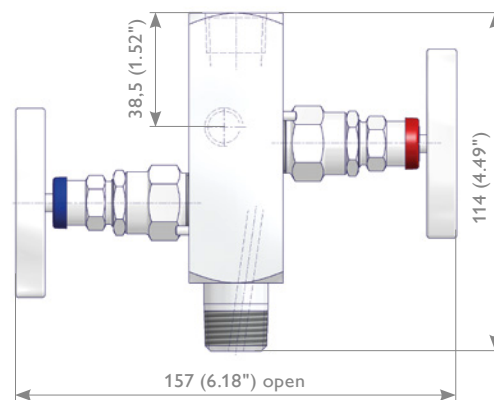
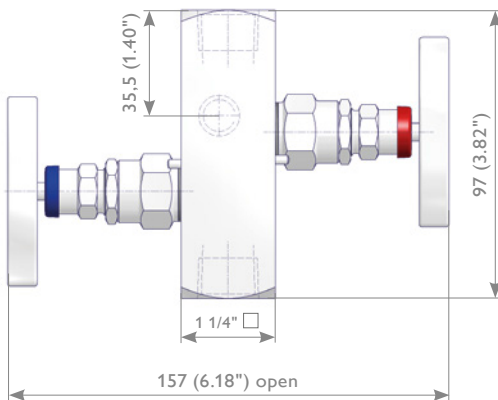

Block & Bleed Manifolds – Male Threaded Instrument Connection

C13ST-2G[]CT Type

1/2 NPT Female Process x 1/2 NPT Male Instrument

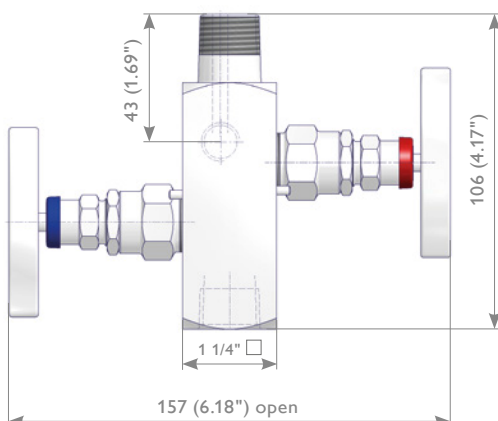

Example for a Typical Installation

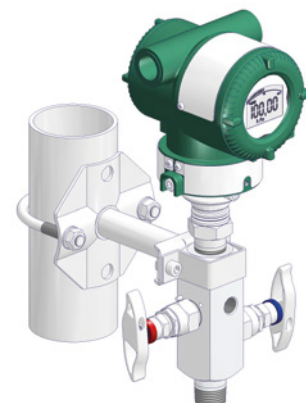

Direct Mount Manifolds

Differential Pressure and Pressure Transmitters with Flanged Body

Direct Mount Manifolds (2, 3 and 5 Valve Manifolds)

Direct Mount Manifolds are designed for direct mounting to Differential Pressure and Pressure Transmitters with Standard Flange Connection in accordance with IEC 61518. A Yokogawa proprietary flange connection for High Pressure Transmitters EJ[]440 is also available optionally on the 2 valve manifolds as well as for the High Pressure Transmitters EJ[]130 on the 3 & 5 Valve Manifolds, but only in Stainless Steel 316. The standard vent connection is 1/4 NPT female. Pipe Plugs are not supplied as standard. For Plugged Vent Ports (factory installed) and other Options see Pages 21 - 23 – Ordering Information.

3 Valve Manifolds are as standard without vent/purge connections.

Following Body Styles are offered:

- **Wafer Style Manifolds & T- Style Manifolds** – Both Manifolds 1/2 NPT Female x Flange
- **H-Style Manifolds** – Flange x Flange

Accessories like Mounting Brackets, Vent Valves, and Pipe Plugs etc. see also Pages 18 - 20.

Direct Mount 2 Valve Manifolds for DPharp Absolute & Gauge Pressure Transmitters

Applicable for Direct Mount DPharp Absolute & Gauge Pressure Transmitters

DPharp Pressure Transmitter Model		Application	Max. allowable (Working) Pressure (PS)		
			MPa	bar	psi
EJX Series	EJX310A	Absolute Pressure	16	160	2,300
EJA Series	EJA310E				
EJX Series	EJX430A	Gauge Pressure	16	160	2,300
EJA Series	EJA430E				
EJX Series	EJX440A	High Gauge	50	500	7,200
EJA Series	EJA440E				

Wafer Style 2 Valve Manifolds – Vent Ports on Bottom Face

1/2 NPT Female x Flanged

This type is basically used for Horizontal Impulse Piping Installations

C13ST-2W[]A1 Type

Isolate Valve as standard on left side (for transmitters with High Pressure on left side)

C13ST-2W[]A2 Type

Isolate Valve optional on right side (for transmitters with High Pressure on right side)

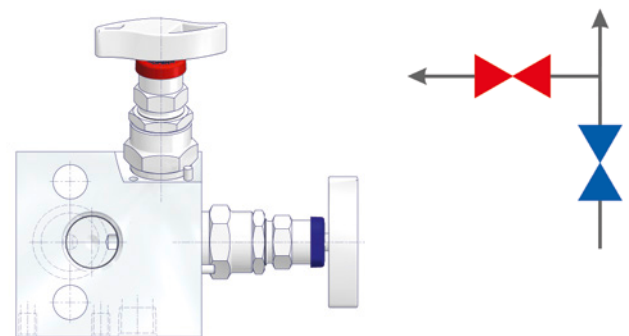
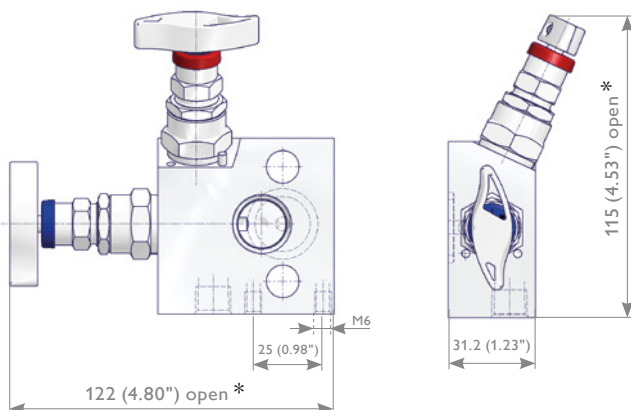

* For High Pressure Type C13ST-2WSY please add 5 mm (0.20")

Wafer Style 2 Valve Manifolds - Vent Ports on Process Side
C13ST-2B[]AB Type
 1/2 NPT Female x Flanged

For direct mounting to Bottom Connection Type Transmitters and for Vertical Impulse Piping Installations

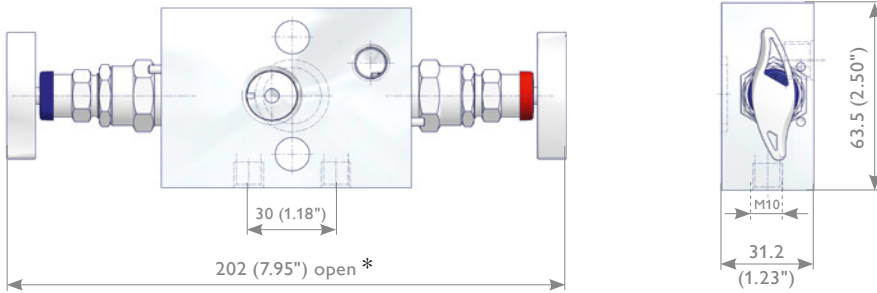

* For High Pressure Type C13ST-2BSY please add 10 mm (0.40")

Example for a Horizontal and Vertical Impulse Piping Installation

Example for a Bottom Connection Type Transmitter

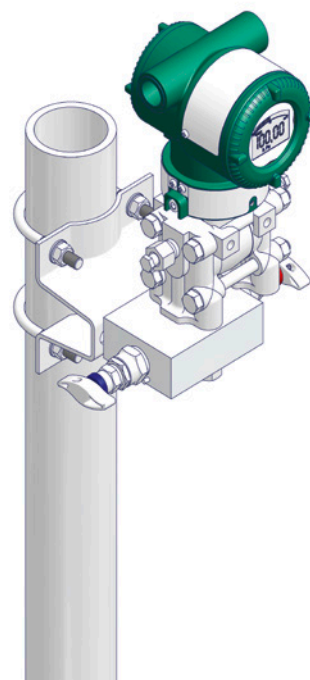
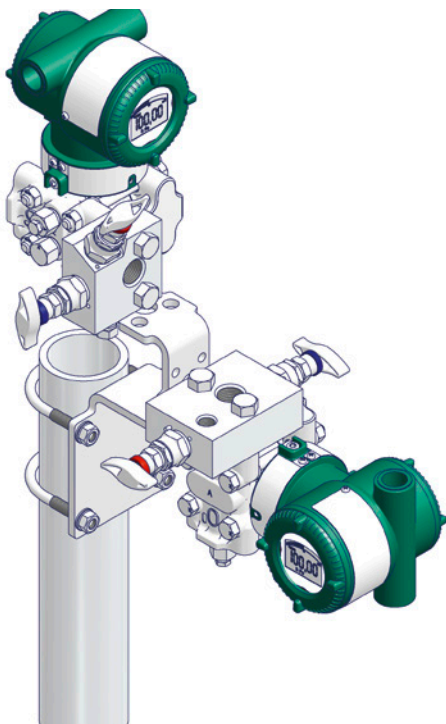

Direct Mount 2 Valve Manifolds

T-Style 2 Valve Manifolds
C13ST-2T[]A1 Type
1/2 NPT Female x Flanged

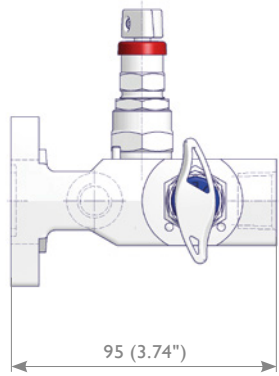
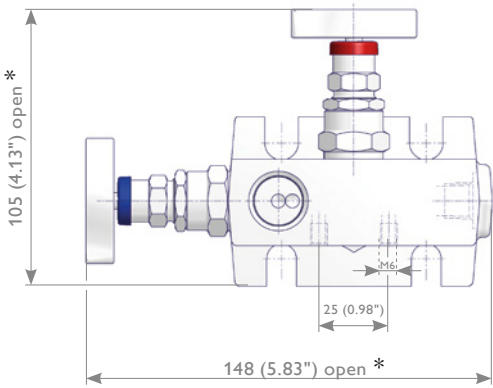

T-Style 2 Valve Manifolds
C13ST-2T[]A2 Type
Isolate Valve optional on right side

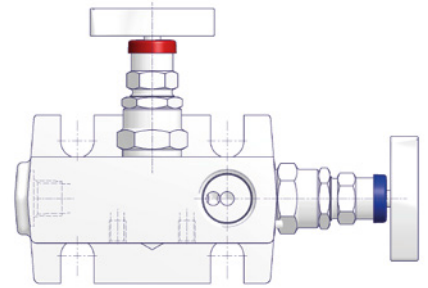

H-Style 2 Valve Manifolds
C13ST-2H[]B1 Type
Flanged x Flanged

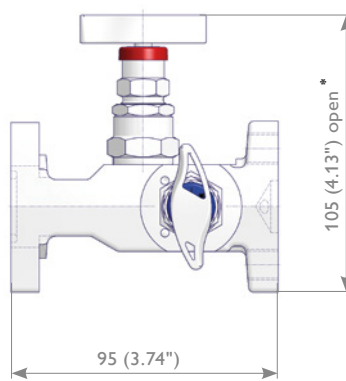
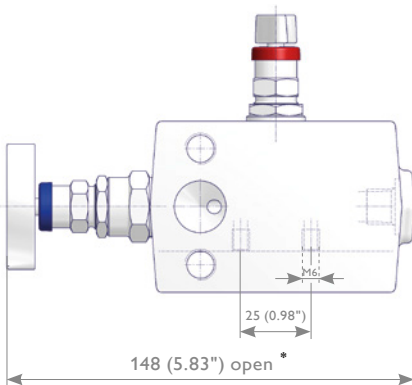

H-Style 2 Valve Manifolds
C13ST-2H[]B2 Type
Isolate Valve optional on right side

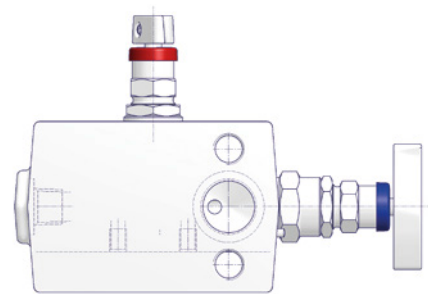

* For High Pressure Type C13ST-2TSY Resp. C13ST-2HSW please add 5 mm (0.20")

Examples for Horizontal and Vertical Impulse Piping Installations



Direct Mount 3 Valve Manifolds

Direct Mount 3 Valve Manifolds for DPharp Differential Pressure Transmitters

3 Valve Manifolds applicable for Direct Mount DPharp Differential Pressure Transmitters

DPharp Pressure Transmitter Model		Application	Max. allowable (Working) Pressure (PS)		
			MPa	bar	psi
EJX Series	EJX110A	Differential Pressure	25	250	3,600
EJA Series	EJA110E		16	160	2,300
EJX Series	EJX120A	Draft Range	0.05	0.5	7.25
EJA Series	EJA120E				
EJX Series	EJX130A	Differential Pressure (High Static)	32	320	4,500
EJA Series	EJA130E				
EJX Series	EJX910A	Multivariable Transmitter	25	250	3,600
	EJX930A		32	320	4,500

Wafer Style 3 Valve Manifolds

C13ST-3W[]A0 Type
1/2 NPT Female x Flanged

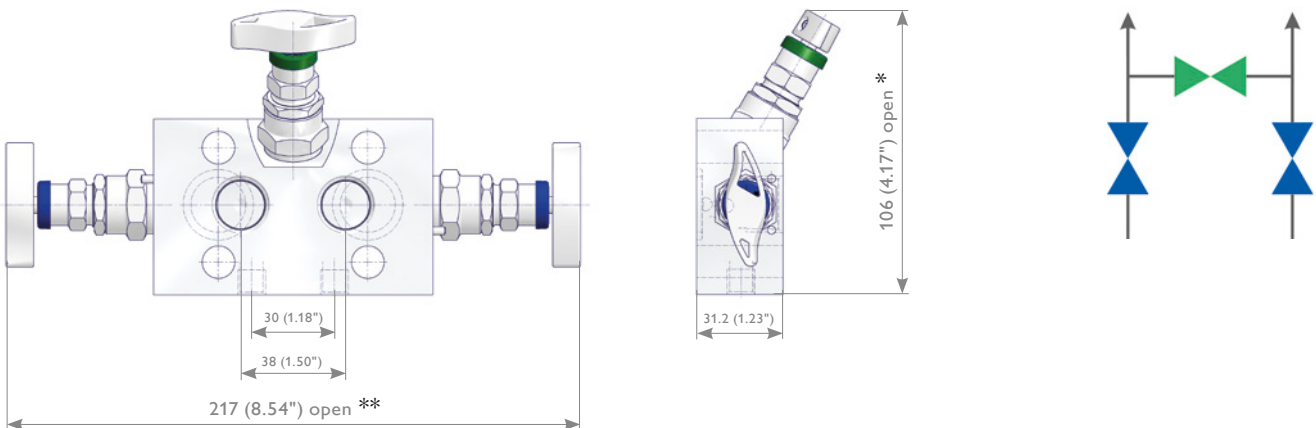

- * For High Pressure Type C13ST-3WSY please add 5mm (0.20")
- ** For High Pressure Type C13ST-3WSY please add 10 mm (0.40")

Example for a Horizontal and Vertical Impulse Piping Installation

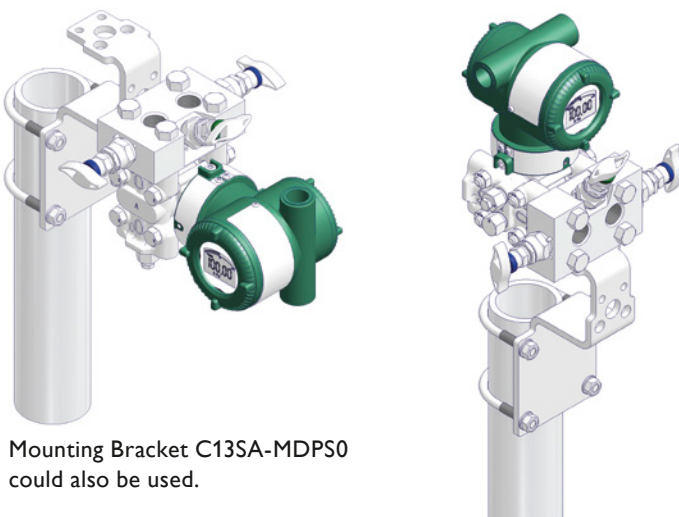

Mounting Bracket C13SA-MDPS0 could also be used.

Example for a Bottom Connection Type Transmitter

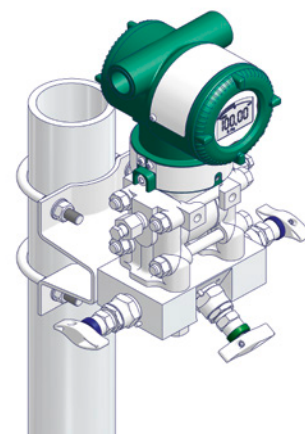

Direct Mount 3 Valve Manifolds

T-Style 3 Valve Manifolds

C13ST-3T[]A0 Type
1/2 NPT Female x Flanged

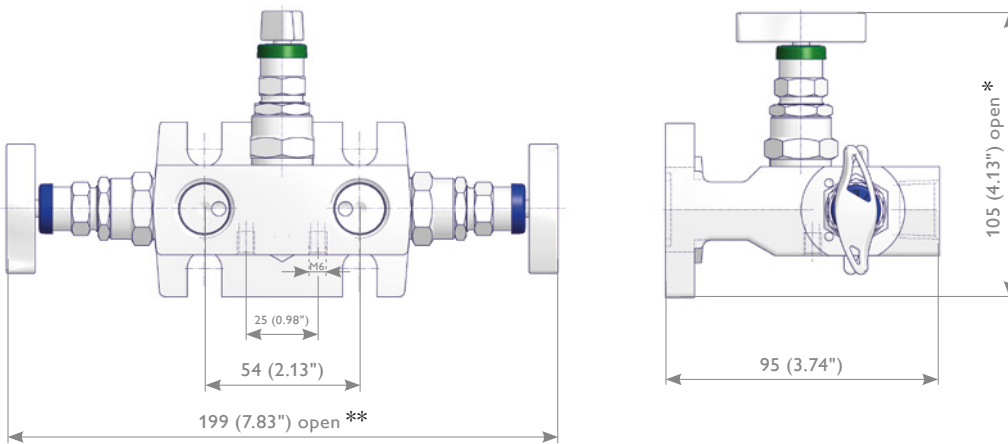

H-Style 3 Valve Manifolds

C13ST-3H[]B0 Type
Flanged x Flanged

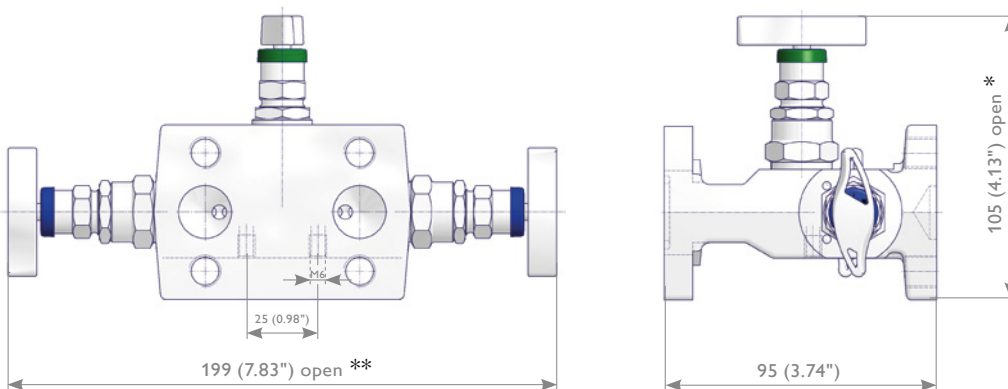

- * For High Pressure Type C13ST-3TSY resp. C13ST-3HSW please add 5 mm (0.20")
- ** For High Pressure Type C13ST-3TSY resp. C13ST-3HSW please add 10 mm (0.40")

Examples for Horizontal and Vertical Impulse Piping Installations



Direct Mount 5 Valve Manifolds

Direct Mount 5 Valve Manifolds for DPharp Differential Pressure Transmitters

5 Valve Manifolds applicable for Direct Mount DPharp Differential Pressure Transmitters

DPharp Pressure Transmitter Model		Application	Max. allowable (Working) Pressure (PS)		
			MPa	bar	psi
EJX Series	EJX110A	Differential Pressure	25	250	3,600
EJA Series	EJA110E		16	160	2,300
EJX Series	EJX120A	Draft Range	0.05	0.5	7.25
EJA Series	EJA120E				
EJX Series	EJX130A	Differential Pressure (High Static)	32	320	4,500
EJA Series	EJA130E				
EJX Series	EJX910A	Multivariable Transmitter	25	250	3,600
	EJX930A		32	320	4,500

Wafer Style 5 Valve Manifolds - Vent Ports on Bottom Face

C13ST-5W[]A0 Type
1/2 NPT Female x Flanged

This type is basically used for Horizontal Impulse Piping Installations

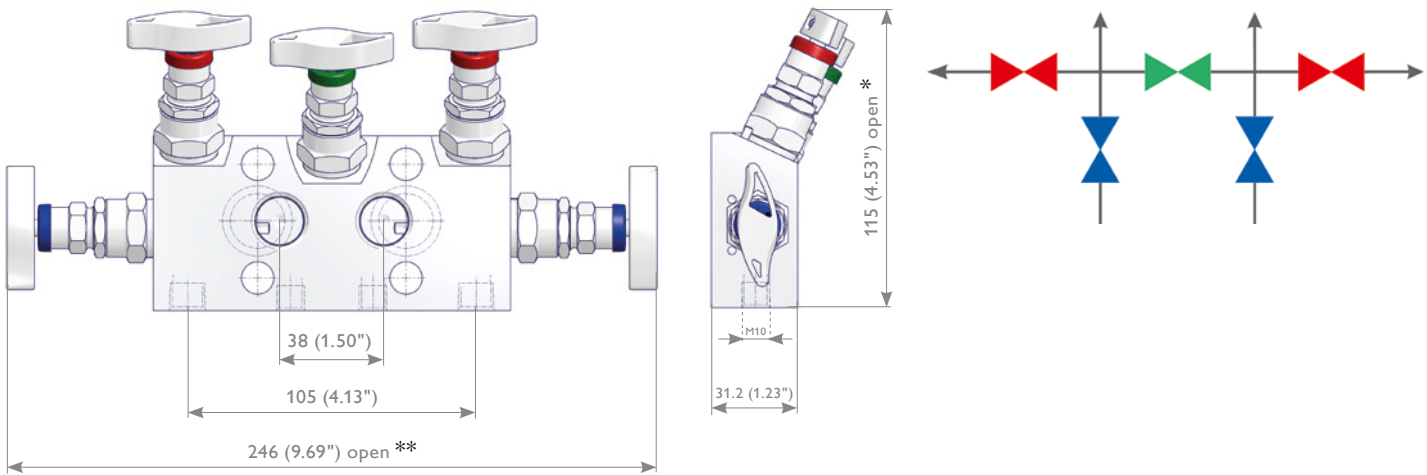

* For High Pressure Type C13ST-5WSY please add 5 mm (0.20")

** For High Pressure Type C13ST-5WSY please add 10 mm (0.40")

Direct Mount 5 Valve Manifolds

Wafer Style 5 Valve Manifolds - Vent Ports on Process Side C13ST-5B[]A0 Type 1/2 NPT Female x Flanged

For direct mounting to Bottom Connection Type Transmitters and for Vertical Impulse Piping Installations

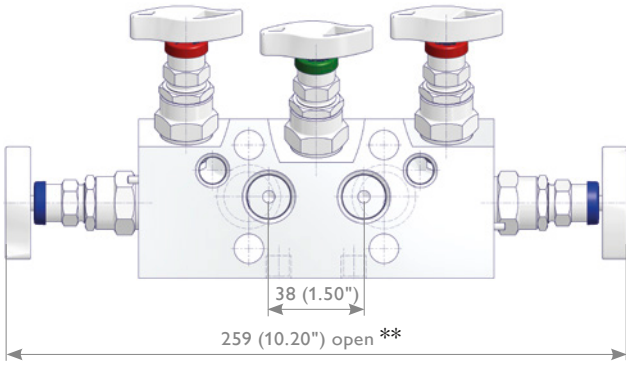

- * For High Pressure Type C13ST-5BSY please add 5 mm (0.20")
- ** For High Pressure Type C13ST-5BSY please add 16 mm (0.63")

Example for a Horizontal and Vertical Impulse Piping Installation

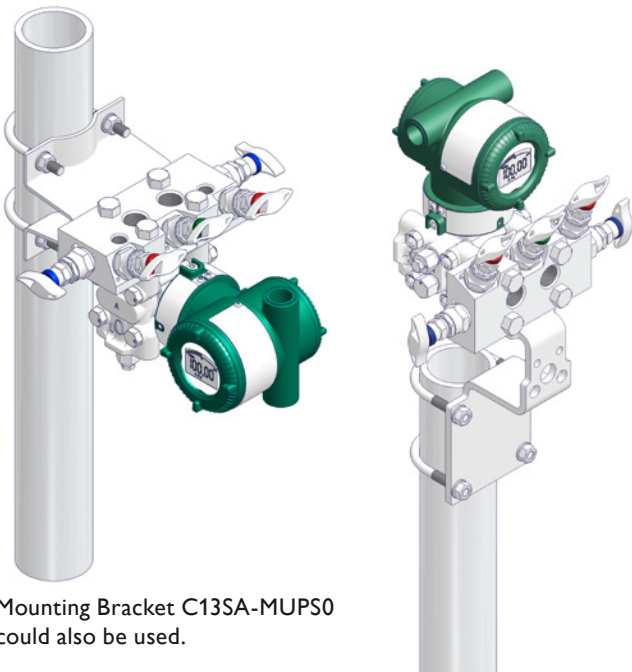

Mounting Bracket C13SA-MUPS0 could also be used.

Example for a Bottom Connection Type Transmitter Installation

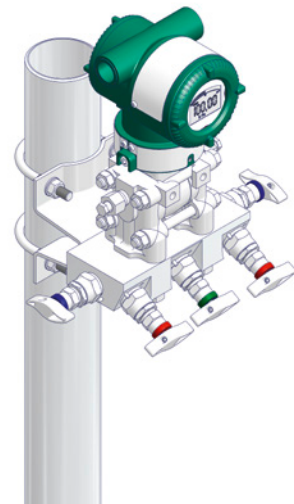

Direct Mount 5 Valve Manifolds

T-Style 5 Valve Manifolds

C13ST-5T[]A0 Type
1/2 NPT Female x Flanged

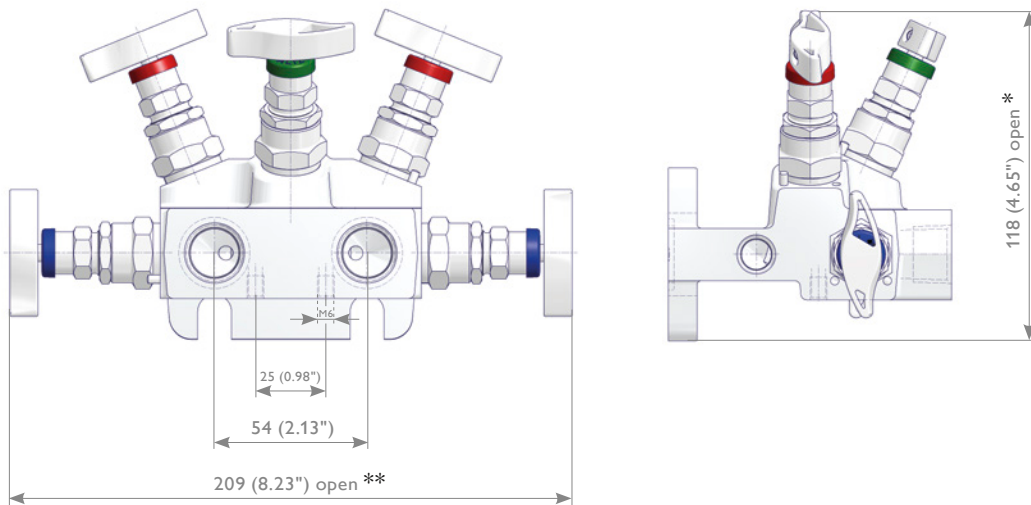

H-Style 5 Valve Manifolds

C13ST-5T[]B0 Type
Flanged x Flanged

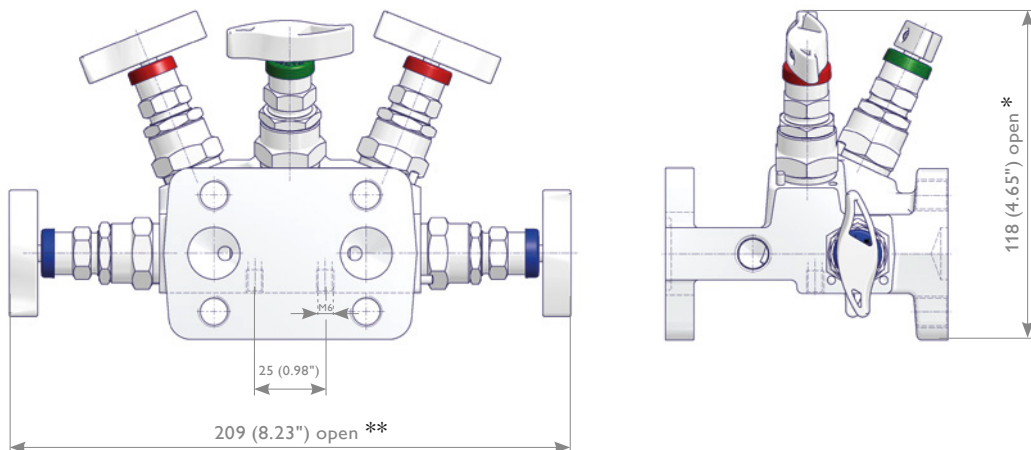

* For High Pressure Type C13ST-5TSY resp. C13ST-5HSW please add 5 mm (0.20")

** For High Pressure Type C13ST-5TSY resp. C13ST-5HSW please add 10 mm (0.40")

Examples for Horizontal and Vertical Impulse Piping Installations



Additional Features

Mounting Bracket Kit for Block & Bleed Manifolds, C13SA-MSPS0

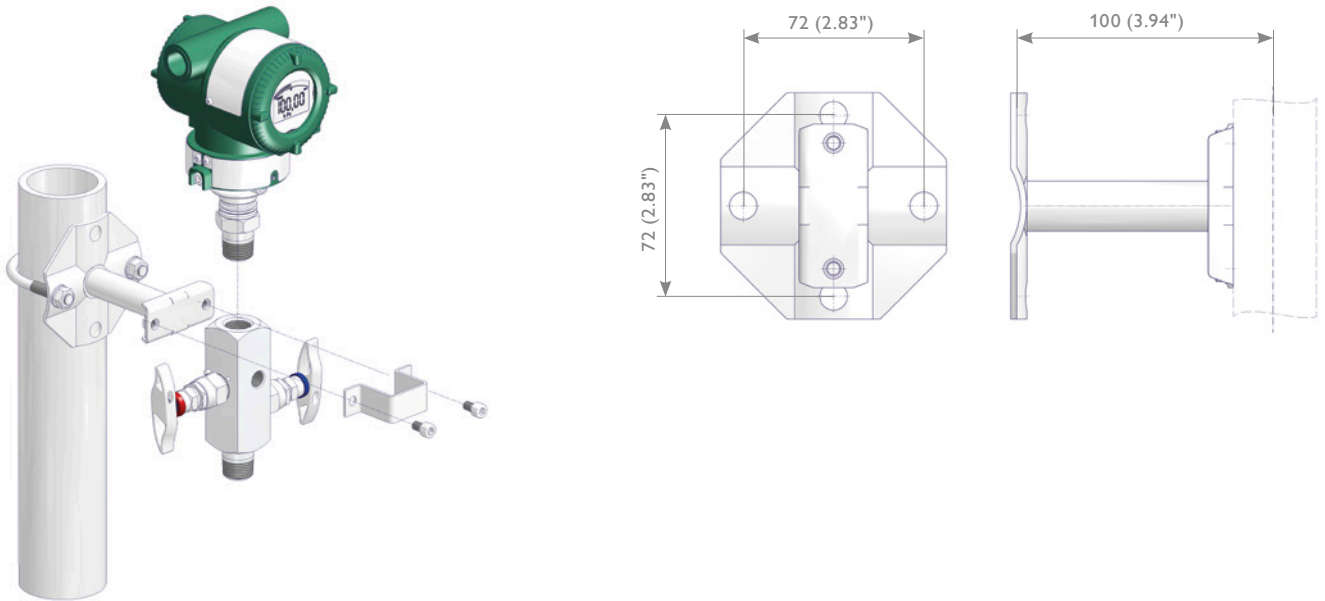

Mounting Bracket Kit for Direct Mount Manifolds – Wafer & T-Style Bodies, C13SA-MUPS0

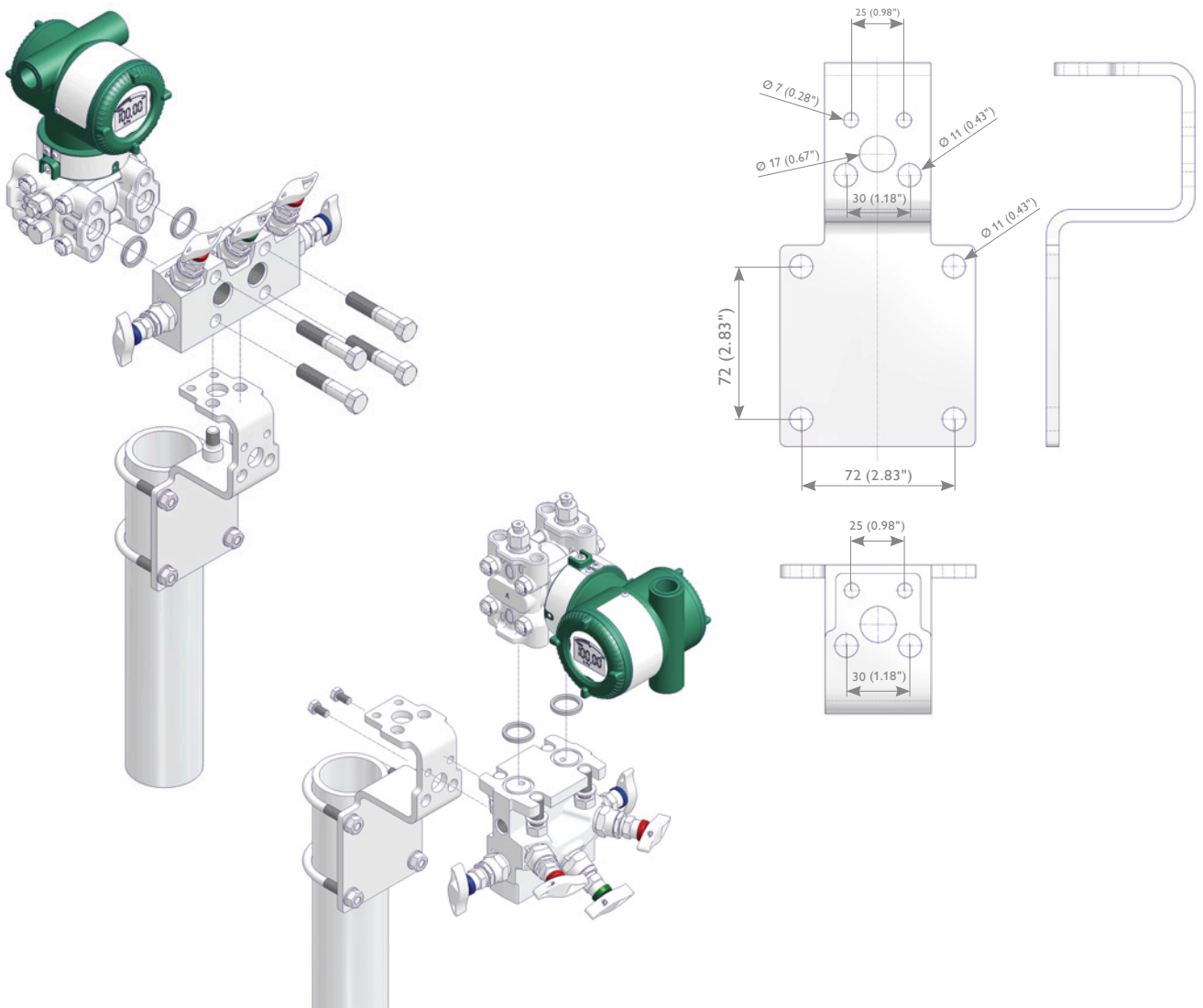

Mounting Bracket Kit for Direct Mount Wafer Style Manifolds and Bottom Connection Type Transmitter, C13SA-MDPS0

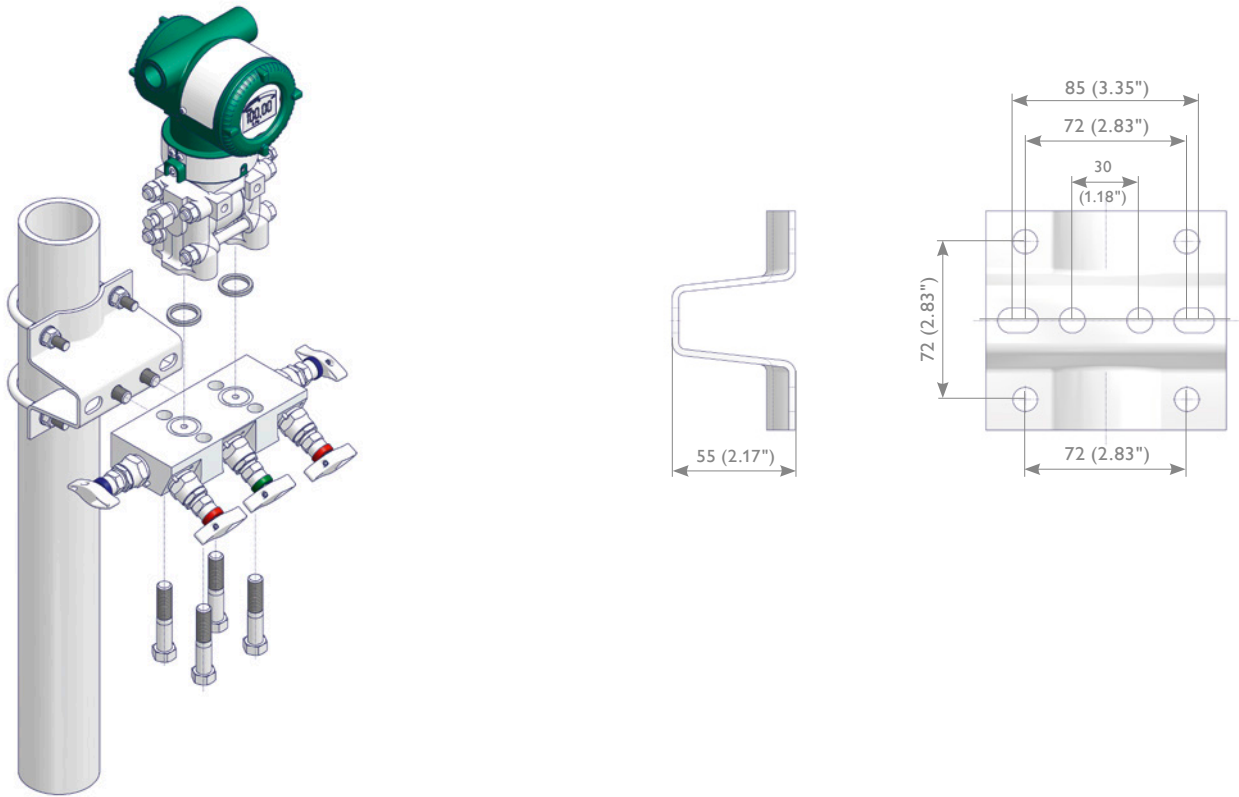

Mounting Bracket Kit for Direct Mount Manifolds – H-Style Bodies, C13SA-MUPSH

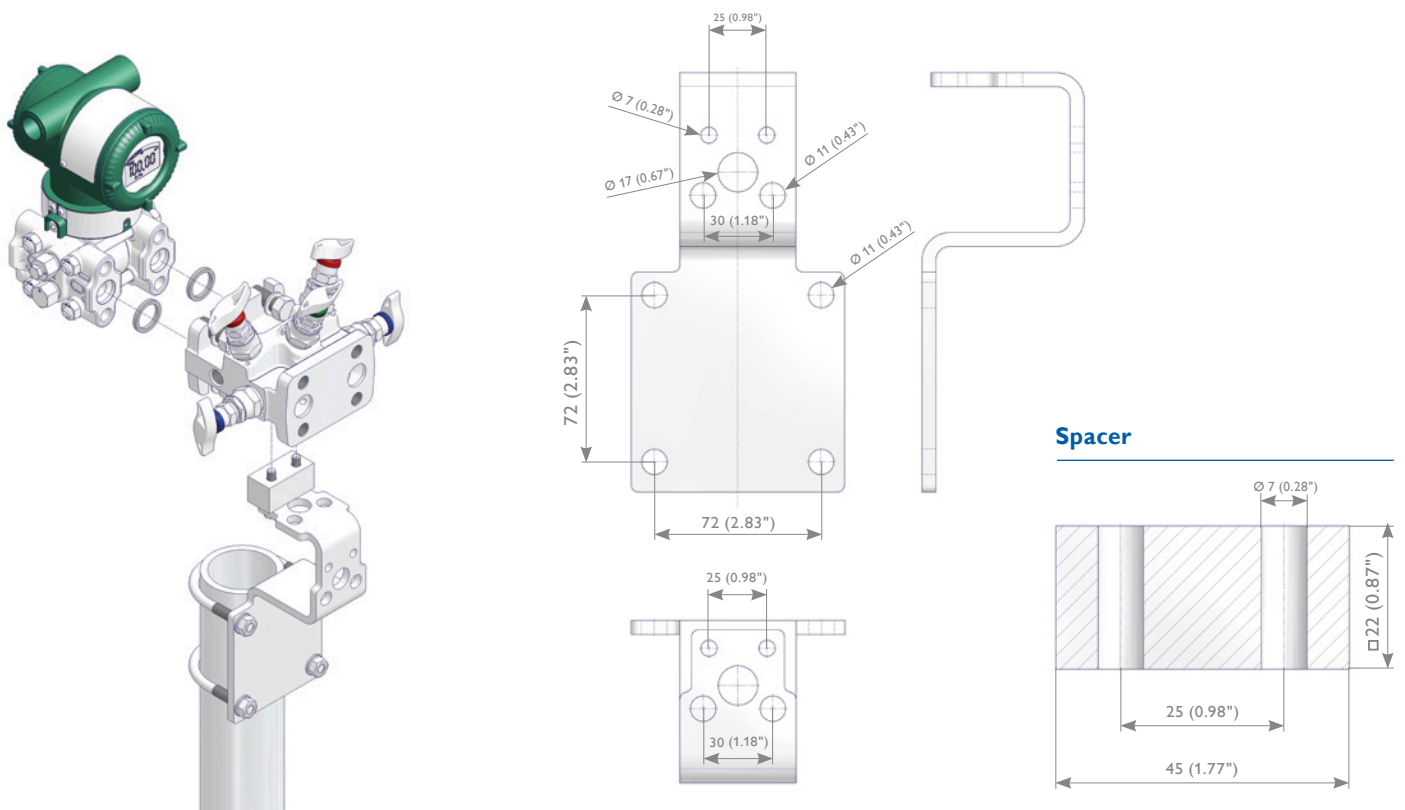

Additional Features / Accessories

Mounting Bracket Kits for Protective Shade Installation Applications, C13SA-MKPS0 / C13SA-MKPS1

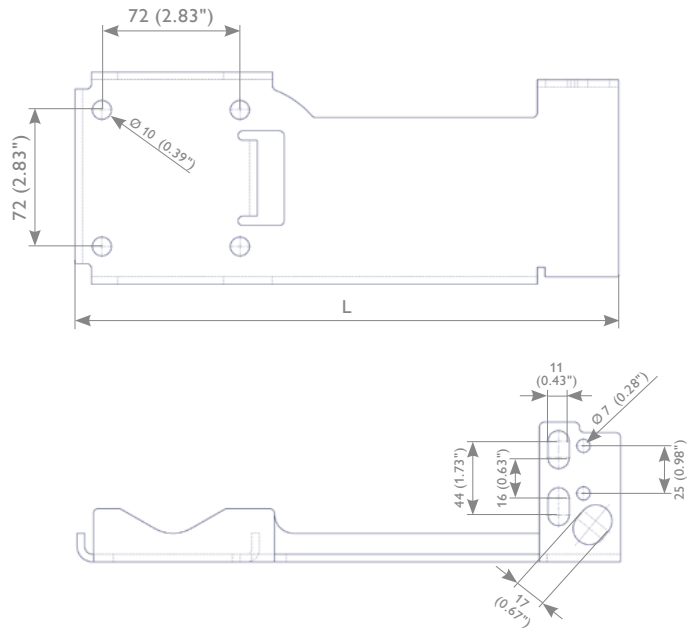
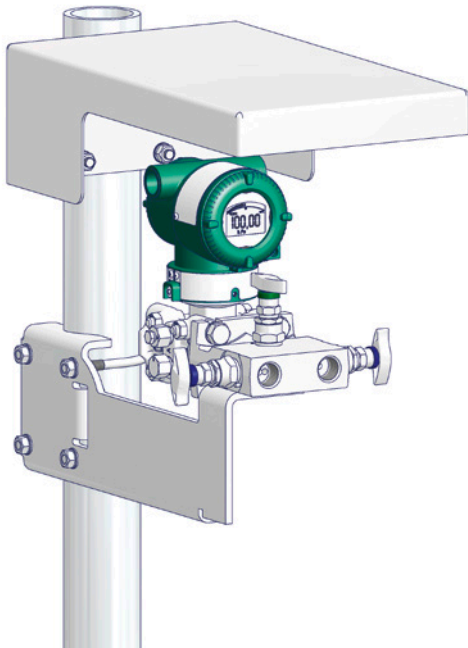

Mounting Bracket Kits are available in 2 different lengths:

For Standard Pressure Transmitters, L = 248mm (11.81")
C13SA-MKPS0

For High Pressure Transmitters, EJ[] 130, EJ[]440, L = 329mm (12.95")
C13SA-MKPS1

The Protective Shades are available in 2 materials:

- Glass Fibre Reinforced Polyester (G.R.P.), Antistatic type, C13SA-PSPG0 and
- 316 Stainless Steel, C13SA-PSPS0

Mounting Bracket and Protective Shades are supplied each with 2 'U' Bolts in 316 SST except the G.R.P. Protective Shade (only 1 'U' Bolt required).

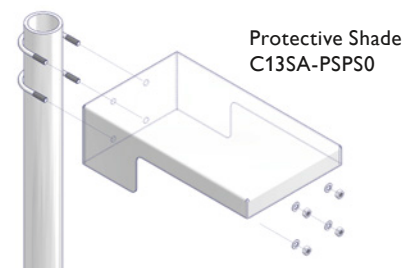

Accessories

(see also Pages 21 - 23 – Ordering Information)

1/4 NPT Pipe Plugs and Vent Valves

Pipe Plug



Vent Valve



Process Connector for H-Style Manifolds only:
Flange Connection acc. to IEC 61518 Type B x 1/2 NPT Female
(Not applicable to Connection Type Code W.)

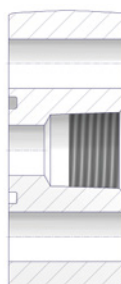

Process Connector and Mounting Kit added separately.

	Model	Suffix Codes	Description			
Standard Features	C13ST	Manifold (AS-Schneider) – Traditional Mounting			
	Body Type & Material	-2	2 Valve		
		-3	3 Valve		
		-5	5 Valve		
		W	Wafer Style - Vent Ports on Bottom Face		
		B	Wafer Style - Vent Ports on Process Side		
		T	T-Style		
		H	H-Style		
		G	Block & Bleed Manifold		
		S	SS 316/316L		
		H	Alloy C-276		
		M	Alloy 400		
		E	Duplex S31803		
		W	Super Duplex S32750		
		C	Alloy 625		
Connection Types						
	For Wafer & T-Style Body	A	Process Side	Instrument Side	
		Y	1/2 NPT Female	Flange Connection (IEC 61518-B) Flange Connection for HP Type (MCHP)*	
	H-Style Body	B	Flange Connection IEC 61518	Flange Connection (IEC 61518-B) Flange Connection for HP Type (MCHP)*	
W		Flange Connection PCHP*			
For Block & Bleed Manifold	C	1/2 NPT Female	1/2 NPT Male 1/2 NPT Female 1/2 NPT Female		
	D	1/2 NPT Female			
	E	1/2 NPT Male			
Installation	0	Always '0' for 3 Valve and 5 Valve			
	1	Left Side High Pressure (for 2 Valve Manifold, except C13ST-2B)			
	2	Right Side High Pressure (for 2 Valve Manifold, except C13ST-2B)			
	B	Always 'B' for 2 Valve Manifold, C13ST-2B			
	T	Always 'T' for Block & Bleed Manifold			
	Model	Suffix Codes	Description			
Additional Features	Bolting	-S2	For 2 Valve, Wafer Style (2 Bolts), SS 316		
		-S4	For Other Styles (4 Bolts), SS 316		
		-N2	For 2 Valve, Wafer Style (2 Bolts), ASTM A453 Grade 660, Class D		
		-N4	For Other Styles (4 Bolts), ASTM A453 Grade 660, Class D		
		-NN	Carbon Steel Bolts as Standard (always 'NN' – None for Block & Bleed Manifold)		
	Bonnet Options					
		PTFE Packing	-NN	Standard	
		Graphite Packing, MWP 500 bar	-G2	For 2 Valve	
			-G3	For 3 Valve	} Not available for High Pressure Type H-Style Manifolds
			-G5	For 5 Valve	
		Power Piping ASME B31.1 - Graphite Packing, MWP 500 bar	-P2	For 2 Valve	
			-P3	For 3 Valve	
			-P5	For 5 Valve	
		ISO FE Type 1 - Graphite Packing + O-Ring Stem Seal, MWP 420 bar	-D2	For 2 Valve	} Not available for High Pressure Type H-Style Manifolds
			-D3	For 3 Valve	
-D5			For 5 Valve		
ISO FE Type 3 - Reinforced PTFE Packing, MWP 420 bar	-E2	For 2 Valve			
	-E3	For 3 Valve			
	-E5	For 5 Valve			
TA-Luft - Reinforced PTFE Packing, MWP 420 bar	-W2	For 2 Valve			
	-W3	For 3 Valve			
	-W5	For 5 Valve			
Arctic Operations -55°C (-67°F) – PTFE Packing	-L2	For 2 Valve			
	-L3	For 3 Valve			
	-L5	For 5 Valve			

* For Transmitters with MWP ≥ 320 bar to ≤ 500 bar and Body Material SS 316 / 316L only. Definition of MCHP- / PCHP-Style see Page 7.

Ordering Information

	Model	Suffix Codes	Description
Additional Features	Pipe Plugs / Vent Plugs	P	Pipe Plug
		V	Vent Valve
		S	SS 316/316L
		H	Alloy C-276
		M	Alloy 400
		E	Duplex S31803
		W	Super Duplex S32750
		C	Alloy 625
		1	For 1 Port, 2 Valve
	2	For 2 Ports, 5 Valve	
	N N N	Without Plugs as Standard	
	Cleaning for Oxygen Service – For Manifolds with PTFE Packing only - Bonnet Option Code -NN or -L[], MWP 420 bar	-K2	For 2 Valve
		-K3	For 3 Valve
		-K5	For 5 Valve
		-NN	None
Valve Operator			
Handwheel	H2	For 2 Valve	
	H3	For 3 Valve	
	H5	For 5 Valve	
Handwheel with Locking Plate Design	L2	For 2 Valve	
	L3	For 3 Valve	
	L5	For 5 Valve	
Anti-Tamper with Key	R2	For 2 Valve	
	R3	For 3 Valve	
	R5	For 5 Valve	
Anti-Tamper without Key	T2	For 2 Valve	
	T3	For 3 Valve	
	T5	For 5 Valve	
PMI Test Report	/P	For 2, 3, 5 and Block and Bleed Valve	

Example for building up the Part No. of a 5 Valve Wafer Style Manifold acc. to the above mentioned Ordering Information:

C13ST-5WSA0-S4-NNPS2-NNNN	Manifold (AS-Schneider) - Traditional Mounting
C13ST-5	5 Valve Manifold
..... W	Body Type: Wafer Style – Vent Ports on Bottom Face
..... S	Material: SS 316/316L
..... A	Process Side: 1/2NPT Female Connection, Instrument Side: Flange Connection (IEC 61518-B)
..... 0	Always '0' for 5 Valve Manifolds
..... -S4	Bolting: SS 316
..... -NN	Bonnet Option: PTFE Packing as Standard
..... PS2	Pipe Plugs: SS 316, installed in Vent Ports
..... -NN	Cleaning for Oxygen Service: None
..... NN	Valve Operator: Standard (T Handle)

Ordering Information – Accessory

	Model	Suffix Codes	Description
Accessory	C13SA	Accessory for Manifold (AS-Schneider)
	For Traditional Mounting Manifolds	-KF	Process Connector, 1 Process Connector / 2 Bolts / 1 Seal Ring / 1/2 NPT Female Inlet / IEC 61518-B Outlet
		S	SS 316/316L
		H	Alloy C-276
		M	Alloy 400
		E	Duplex S31803
		W	Super Duplex S32750
		C	Alloy 625
		N	Carbon Steel Bolts as Standard
		S	SS 316 Bolts
		P	Seal Ring, PTFE
		G	Seal Ring, Graphite
		-MSPS0	Mounting Bracket for Block & Bleed Manifold, SS 316
		-MUPS0	Mounting Bracket for Wafer / T-Style Manifold, SS 316
	-MUPSH	Mounting Bracket for H-Style Manifold, SS 316	
	-MDPS0	Mounting Bracket for Wafer Style Manifolds and Vertical Impulse Piping Installations	
	-MKPS0	Mounting Bracket for Protective Installation Applications, Standard Transmitter	
	-MKPS1	Mounting Bracket for Protective Installation Applications, High Pressure Type Transmitter	
	-PSPGO	Protective Shade, G.R.P. Antistatic	
	-PSPSO	Protective Shade, SS316	
Common	-ATKES	Anti-Tamper Key	
	-SRPBN	Seal Ring, PTFE, IEC B	
	-SRPYN	Seal Ring, Reinforced PTFE, Special Connection for High Pressure Type	
	-SRGBN	Seal Ring, Graphite, IEC B	

Products are designed and manufactured by Armaturenfabrik Franz Schneider (AS-Schneider) for Yokogawa Electric Corporation.

ARMATURENFABRIK FRANZ SCHNEIDER GMBH + CO. KG
World Headquarters
Bahnhofplatz 12, 74226 Nordheim, Germany
Tel: +49 7133 101-0
<http://www.as-schneider.com>

AS-SCHNEIDER ASIA-PACIFIC PTE. LTD.
970 Toa Payoh North, #02-12/14/15, Singapore 318992,
Singapore
Tel: +65 62 51 39 00
<http://www.as-schneider.sg>

ARMATURENFABRIK FRANZ SCHNEIDER SRL
Str. Basarabilor, Nr. 7, 100036 Ploiesti, Romania
Tel: +40 244 384 963
<http://www.as-schneider.ro>

AS-SCHNEIDER AMERICA, INC.
17471 Village Green Dr, Houston, TX 77040, U.S.A.
Tel: +1 281 760 1025
<http://www.as-schneider.com>

AS-SCHNEIDER MIDDLE EAST FZE
P.O. Box 18749, Dubai, United Arab Emirates
Tel: +971 4 880 85 75
<http://www.as-schneider.ae>



YS-2601-EN | December 2019 / 5th Edition

DPharp® EJK® EJA® are registered trademarks of Yokogawa Electric Corporation.
Other company names and product names used in this material are registered trademarks or trademarks of their respective owners.

YOKOGAWA ELECTRIC CORPORATION
World Headquarters
2-9-32, Nakacho, Musashino-shi, Tokyo 180-8750, Japan
<http://www.yokogawa.com>

YOKOGAWA CORPORATION OF AMERICA
2 Dart Road, Newnan, GA30265, U.S.A.
<http://www.yokogawa.com/us/>

YOKOGAWA EUROPE B.V.
Euroweg 2, 3825 HD Amersfoort, The Netherlands
<http://www.yokogawa.com/eu/>

YOKOGAWA ENGINEERING ASIA PTE. LTD.
5 Bedok South Road, Singapore 469270
<http://www.yokogawa.com/sg/>

YOKOGAWA CHINA CO., LTD.
3F TowerD Cartelo Crocodile Building, No. 568 West Tianshan Road,
Shanghai 200335, China
<http://www.yokogawa.com/cn/>

YOKOGAWA MIDDLE EAST B.S.C.(c)
P.O. Box 10070, Manama
Building 577, Road 2516, Busaiteen 225, Muharraq, Bahrain
<http://www.yokogawa.com/bh/>

Represented by:

