

General Specifications

ZR22G, ZR802G, and ZR202G
Zirconia Oxygen/Humidity Analyzer

GS 11M12G01-01EN

Overview

This analyzer consists basically of a probe and a converter that are used as both a Zirconia Oxygen Analyzer and High Temperature Humidity Analyzer.

Two types are available direct insertion zirconia oxygen analyzer.

The separate type which consists ZR22G of detector and ZR802G of converter.

The integrated type ZR202G combining detector and converter.

Separate and integrated type Zirconia oxygen analyzers do not need a sampling device, and allow direct installation of the probe in the wall of a flue or furnace to measure the concentration of oxygen in the stack gas.

The ZR802G converter uses a digital display, displays the cell temperature and cell emf in addition to the oxygen concentration and includes a Human Machine Interface (HMI), that offers easy touch screen operation.

This analyzer is most suitable for monitoring the oxygen concentration of combustion gases in large or small boilers, various industrial furnace and combustion devices, or for the control of low-oxygen combustion.

Separate type and integrated type Zirconia High Temperature Humidity Analyzers are used to measure the humidity of hot gases continuously in driers which use an electrical heater or hot gas as the heat source. They can also be used in a variety of manufacturing applications in humidifiers, as well as in driers, for humidity measurement and control. They can help improve productivity in these application fields.

Features:

- The built-in heater assembly of the probe can be replaced on site, reducing maintenance costs.
- The probe uses a long-life, high-reliability Zirconia sensor.
- The probe uses three-reference gas supply methods (natural air convection, instrument air, and pressure compensated) in its applications.



- The converter incorporates the LCD touchscreen for ease of operation.
- The converter can be used as an oxygen analyzer as well as a high temperature humidity analyzer.
- The deterioration status of the sensor can be confirmed by the sensor resistance check function (self-diagnosis function) in the converter.
- The converter records history of alarm on/off, measured value history for up to 41 days, and others.
- The integrated type integrates both probe and converter, to reduce wiring, piping, and installation costs. This type of unit uses an optical switch for ease of operation at the site.
- Remote maintenance using digital communications (HART, Modbus RTU) reduces maintenance costs. *1

*1: HART is a registered trademark of HART Communication Foundation

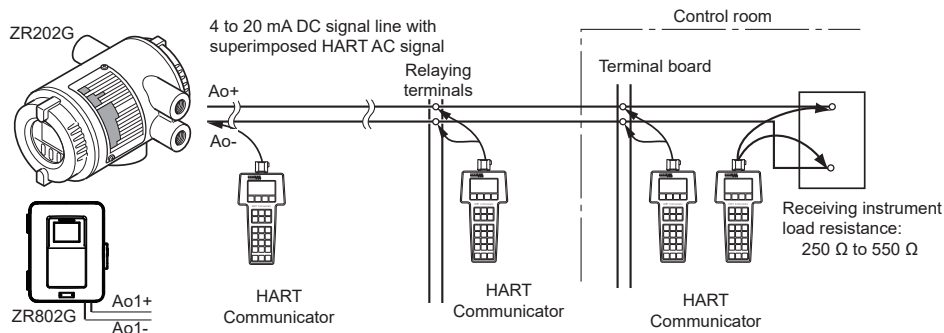

All other company and product names mentioned in this document are trademarks or registered trademarks of their respective companies.

Basic System Configuration

System configuration - Separate type

System configuration Example 1 of Separate type Analyzer

- Automatic calibration system uses instrument air for reference gas.
For the calibration gas, a standard gas cylinder may be used for more accurate calibration.
- Applications: Oxygen concentration monitoring and control in large boilers (for private power generation and for business use) and in heating furnaces, and the like.
Humidity monitoring and control in drying furnaces and humidifiers.

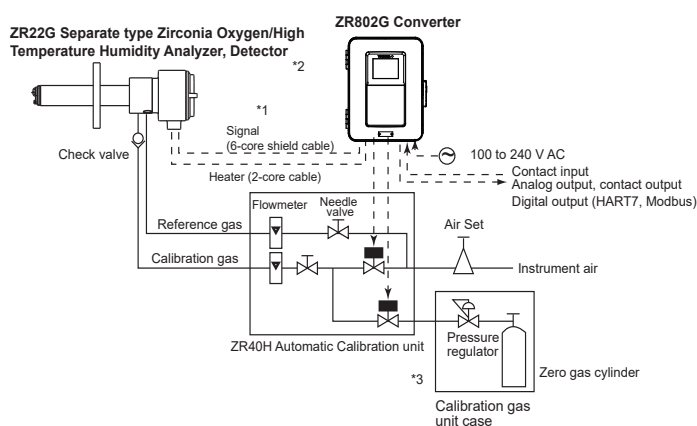

System configuration - Integrated type

System configuration Example 1 of Integrated type Analyzer

- Automatic calibration system uses instrument air for reference gas.
For the calibration gas, a standard gas cylinder may be used for more accurate calibration.
- Applications: Oxygen concentration monitoring and control in large boilers (for private power generation and for business use) and in heating furnaces, and the like.
Humidity monitoring and control in drying furnaces and humidifiers.

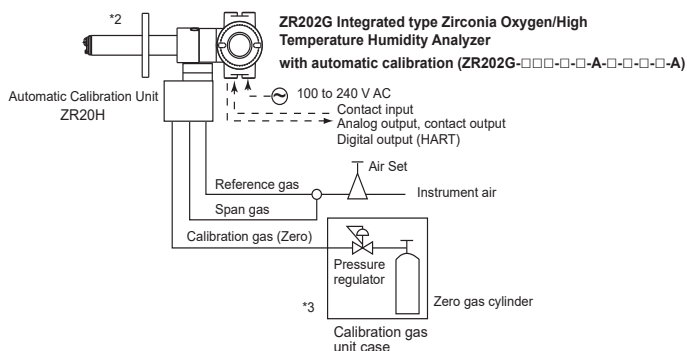

Note:
The installation temperature limits range for integrated type analyzer is -20 to 55°C.

- *1 Shield cable:
Use shielded signal cables, and connect the shields to the FG terminal of the converter.
- *2 Select the desired probe from the Probe Configuration table on page 4.
- *3 When a zirconia oxygen analyzer is used, 100% N₂ gas cannot be used as the zero gas. Use approx. 1 vol% O₂ gas (N₂-balanced).

Basic System Configuration

System configuration — Separate type

System configuration Example 2 of Separate type Analyzer

- Instrument air is used as the reference gas. A standard gas cylinder can be used for the calibration gas for more accurate calibration.
- Application example: Oxygen concentration monitoring and control in large boilers (for private power generation and for business use) and in heating furnaces. Humidity monitoring and control in drying furnaces and humidifiers.

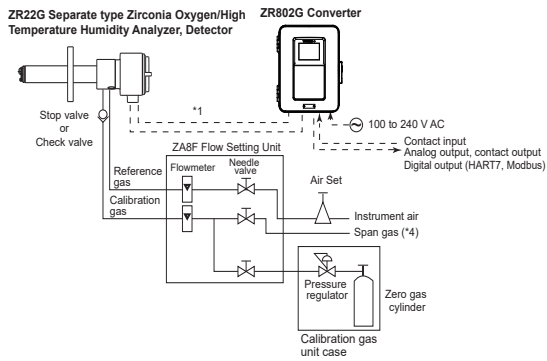

*1 Shield cable:
Use shielded signal cables, and connect the shields to the FG terminal of the converter.
*4 Calibration gas unit same as for zero gas.

System configuration Example 3 of Separate type Analyzer

- Ambient air is used as the reference gas. A portable standard gas unit (ZO21S) is used for the calibration. This unit is connected only when the calibration is made.
- Application example:
Oxygen concentration monitoring and control in packaged boilers
Humidity monitoring and control in drying furnaces or a humidifiers

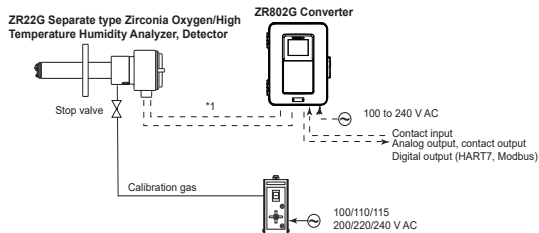

*1 Shield cable:
Use shielded signal cables, and connect the shields to the FG terminal of the converter.

System configuration — Integrated type

System configuration Example 2 of Integrated type Analyzer

- Instrument air is used as the reference gas. A standard gas cylinder can be used for the calibration gas for more accurate calibration.
- Application example: Oxygen concentration monitoring and control in large boilers (for private power generation and for business use) and in heating furnaces. Humidity monitoring and control in drying furnaces and humidifiers.

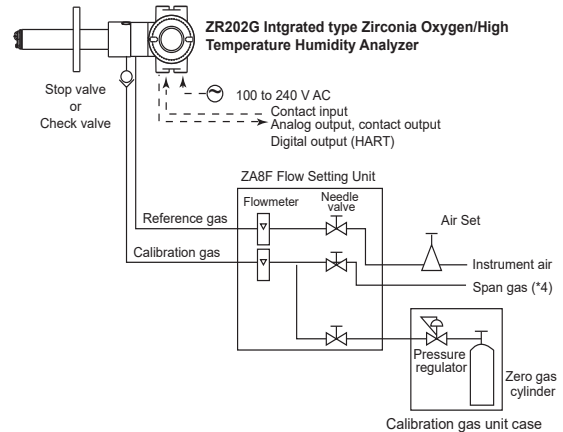

System configuration Example 3 of Integrated type Analyzer

- Ambient air is used as the reference gas. A portable standard gas unit (ZO21S) is used for the calibration. This unit is connected only when the calibration is made.
- Application example:
Oxygen concentration monitoring and control in packaged boilers
Humidity monitoring and control in drying furnaces or a humidifiers

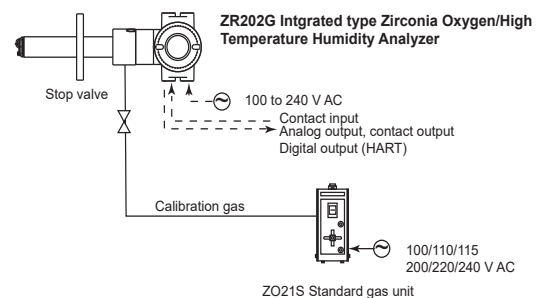

Note: The installation temperature limits range for integrated type analyzer is -20 to 55°C.

System Components

	Model or Part number	System Components	Separate type			Integrated type		
			System config.			System config.		
			Ex.1	Ex.2	Ex.3	Ex.1	Ex.2	Ex.3
1	ZR22G	Zirconia Oxygen/Humidity Analyzer, Detector	●	●	●			
2	ZR802G	Zirconia Oxygen/Humidity Analyzer, Converter	●	●	●			
3	ZR202G	Integrated type Zirconia Oxygen/Humidity Analyzer				●	●	●
4	ZO21P-H	High Temperature Probe Adapter for Oxygen Analyzer	○	○	○			
5	E7046EC/E7046EN	Ejector Assembly for High Temperature Probe of Oxygen Analyzer	○	○	○			
6	ZO21R-L	Probe Protector for Oxygen Analyzer	○	○	○	○	○	○
7	K9471UA	Dust Filter for Oxygen Analyzer	○	○	○	○	○	○
8	K9471UC	Dust Guard Protector for Oxygen Analyzer	○	○	○	○	○	○
9	ZH21B	Dust Protector for Humidity Analyzer	○	○	○	○	○	○
10	ZO21S	Standard Gas Unit			●			●
11	ZA8F	Flow Setting Unit for manual calibration		●			●	
12	ZR40H	Automatic Calibration Unit for ZR802G	●			●		
13	ZR20H	Automatic Calibration Unit for ZR202G (*1)						
14	L9852CB/G7016XH	Stop Valve for Calibration gas line (*2)		(●)	●		(●)	●
15	K9292DN/K9292DS	Check Valve for Calibration gas line (*2)	●	(●)			(●)	
16	G7003XF/K9473XK, G7004XF/K9473XG	Air Set	●	●				
17	G7001ZC	Zero gas Cylinder	●	●				
18	G7013XF/G7014XF	Pressure Regulator for Gas Cylinder	●	●				
19	E7044KF	Case Assembly for Calibration-gas Cylinder	●	●				
20	ZR22A	Heater Assembly for ZR22G	○	○	○	○	○	○
21	ZR202A	Heater Assembly for ZR202G						

●: Items required for the above system example

○: To be selected depending on each application. For details, refer to Chapter of Options.

(●): Select either

(*1): When Automatic Calibration of (-A) or (-B) code is specified, ZR20H is installed in ZR202G.

(*2): When ZR22G or ZR202G specifies Stop valve (/SV) or Check valve (/CV) as an option code, they are correspondingly installed in the equipment.

Detector Components

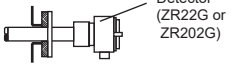
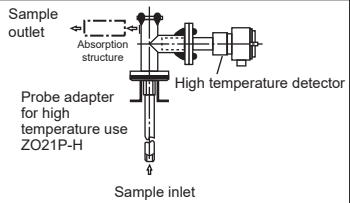
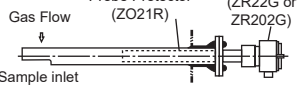
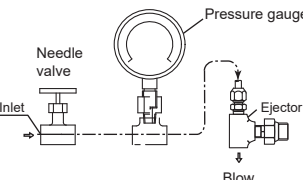
Sample gas temperature 0 to 700°C				Sample gas temperature 700 to 1400°C	
Mounting	Insertion length	General-use Probe	Application	High temperature detector	Application
Horizontal to vertical	0.4 to 2 m		Boiler Heating furnace	 <p>Temperature: Probe material; SUS310S 800°C Probe material; SiC 1400°C Mounting: Vertical downwards Insertion length: 1.0 m, 1.5 m When duct pressure is atmospheric or negative, attach air ejector. High temperature auxiliary ejector assembly (E7046EC, E7046EN)</p>	Heating furnace
Vertical	2.5 m or more				
Horizontal to vertical	3 m or less		For pulverized coal boiler with gas flow velocity 10 m/sec or more		
Horizontal to vertical	0.4 to 2 m	Dust filter for Oxygen Analyzer (K9471UA)	Black liquid recovery boiler Cement Kiln		
Vertical	2.5 m or more	or Dust guard protector (K9471UC)			

■ STANDARD SPECIFICATIONS (Oxygen Analyzer)

Example of Application

Separate and integrated type Zirconia Oxygen Analyzers

- Large, medium and small boilers (boilers for power generation: heavy oil, gas or coal)
- Various industrial furnaces (refinery process/iron manufacture heating furnace, coal kiln, and black liquid recovery boilers) For other applications, contact Yokogawa Electric Corporation.
- May not be applicable corrosive gas such as ammonia, chlorine is present-check with YOKOGAWA.

General Specifications

Measurement Object: Oxygen concentration in combustion exhaust gas and mixed gas (excluding inflammable gases)

Measurement System: Zirconia system

Measurement Range: 0.01 to 100 vol% O₂

Output Signal: 4 to 20 mA DC (maximum load resistance 550 Ω)

Setting Range: Any setting in the range of 0 to 5 through 0 to 100 vol% O₂ (in 1 vol% O₂), or partial range

Display Range: 0 to 100 vol% O₂

Warming-up Time: Approx. 20 min.

Repeatability: (Excluding the case where the reference gas is by natural convection) ± 0.5% F.S. ; range from 0 to 5 vol% O₂ or more and less than 0 to 25 vol% O₂ range ± 1% F.S. ; range from 0 to 25 vol% O₂ or more and up to 0 to 100 vol% O₂ range

Linearity: (Excluding standard gas tolerance and the case where the reference gas is by natural convection) (Use oxygen of known concentration (within the measuring range) as the zero and span calibration gases.)

± 1% F.S.; 0 to 5 or more and less than 0 to 25 vol% O₂ range and sample gas pressure within ± 4.9 kPa
 ± 3% F.S.; 0 to 25 or more and less than 0 to 50 vol% O₂ range and sample gas pressure within ± 0.49 kPa
 ± 5% F.S.; 0 to 50 or more and up to 0 to 100 vol% O₂ range and sample gas pressure within ± 0.49 kPa

Drift: (Excluding the first two weeks in use and the case where the reference gas is by natural convection.)

Both zero and span ± 2% F.S. /month
 Response Time: Response of 90% within 5 seconds. (Measured after gas is introduced from calibration gas inlet and analog output starts changing.)

Safety, EMC, and RoHS conformity standards of ZR22G, ZR802G and ZR202G

Installation altitude: 2000 m or less

Installation category: (IEC61010); II

Pollution degree: (IEC61010); 2

Measurement category: O (other)

- Note
- Installation category, called overvoltage category, specifies impulse withstanding voltage. Category II is for electrical equipment.
 - Pollution degree indicates the degree of existence of solid, liquid, gas or other inclusions

which reduce dielectric strength. Degree 2 is the normal indoor environment.

Safety :

ZR202G/ZR22G;

CE EN 61010-1

EN 61010-2-030

UL UL61010-1:2nd Edition

CSA CAN/CSA-C22.2 No. 61010-1

GB GB30439 Part 1

ZR802G;

CE EN 61010-1/A1

EN 61010-2-030

UL UL61010-1:3rd Edition, AMD1

UL61010-2-030:1st Edition

CSA CAN/CSA-C22.2 No. 61010-1+Amd1

CAN/CSA-C22.2 No. 61010-2-030

GB GB30439 Part 1

EMC:

CE EN 61326-1 Class A Table 2

EN 61326-2-3,

EN 61000-3-2

RCM EN 55011 Class A, Group 1

KC KN11 Class A Group1, KN61000-6-2

- Note
- This instrument is a Class A product, and it is designed for use in the industrial environment. Please use this instrument in the industrial environment only.
 - Influence of immunity environment (Criteria A) : Output shift is specified within ±20% of F.S.

RoHS: EN IEC 63000

Others:

REACH Regulation EC 1907/2006

Information of the WEEE Directive

This product is purposely designed to be used in a large scale fixed installations only and, therefore, is out of scope of the WEEE Directive. The WEEE Directive is only valid in the EU.

1. ZR22G Zirconia Oxygen/Humidity Analyzer, Detector

Sample Gas Temperature: 0 to 700°C (Probe only)

It is necessary to mount the cell using Inconel cell-bolts when the temperature is greater than 600°C.

For high temperature sample gas (700 to 1400°C), apply 0.15 m length probe and High Temperature Probe Adapter ZO21P-H.

Sample Gas Pressure: - 5 to + 250 kPa (No pressure fluctuation in the furnace should be allowed.)

When the pressure in the furnace exceeds 3 kPa, it is recommended to use pressure compensated type.

When the pressure in the furnace exceeds 5 kPa, pressure compensated type is required.

For 0.15 m probe length, - 0.5 to + 5 kPa.

- Note: When the detector is used in conjunction with a check valve and the ZA8F Flow Setting Unit, the maximum pressure of sample gas is 150 kPa. When with a check valve and the ZR40H Automatic Calibration Unit, it is 200 kPa. If the pressure of your sample gas exceeds these limits, consult with Yokogawa.

Probe Length: 0.15, 0.4, 0.7, 1.0, 1.5, 2.0, 2.5, 3.0, 3.6, 4.2, 4.8, 5.4 m

Probe Material: SUS316

Ambient Temperature: -20 to +150°C
 Reference Gas System: Natural Convection,
 Instrument Air, Pressure compensated
 (other than for probe length 0.15 m)
 Instrument Air System (excluding Natural Convection)
 It is recommended to use air which has
 been dehumidified by cooling to dew point
 -20°C or less, and dust or oil mist are
 removed.
 Supply gas pressure; Sample Gas
 pressure: +approx. 50 kPa
 Sample gas pressure + approx. 150 kPa
 (/CV: with check valve)
 Consumption; Approx. 1 NI/min
 Wetted Material: SUS316, Zirconia, SUS304 or
 ASTM grade 304 (flange), Hastelloy B,
 (Inconel 600, 601)
 Construction: Heater and thermocouple replaceable
 construction. Non explosion-proof JIS
 C0920 / equivalent to IP44D. Equivalent
 to NEMA 4X/IP66 (Achieved when the
 cable entry is completely sealed with a
 cable gland in the recirculation pressure
 compensated version.)
 Terminal Box Case Material: Aluminum alloy
 Terminal Box Paint Color:
 Case and Cover; Mint green (Munsell
 5.6BG3.3/2.9)
 Finish: Polyurethane corrosion-resistance coating
 Gas Connection: Rc1/4 or 1/4 NPT (Female)
 Wiring Connection: G1/2, Pg 13.5, M20 × 1.5,
 1/2 NPT
 Installation: Flange mounting
 Probe Mounting Angle: Horizontal to vertically
 downward.
 When the probe insertion length is 2 m or
 less, installing at angles from horizontal to
 vertically downward is possible.
 When the probe insertion length is 2.5
 m or more, mount vertically downward
 (within ±5°) and use a probe protector.
 Weight:
 Insertion length of 0.15 m: approx. 5 kg (JIS 5K 65)
 / approx. 10 kg (ANSI 150 4)
 Insertion length of 0.4 m: approx. 6 kg (JIS 5K 65)
 / approx. 11 kg (ANSI 150 4)
 Insertion length of 1.0 m: approx. 8 kg (JIS 5K 65)
 / approx. 13 kg (ANSI 150 4)
 Insertion length of 1.5 m: approx. 10 kg (JIS 5K 65)
 / approx. 15 kg (ANSI 150 4)
 Insertion length of 2.0 m: approx. 12 kg (JIS 5K 65)
 / approx. 17 kg (ANSI 150 4)
 Insertion length of 3.0 m: approx. 15 kg (JIS 5K 65)
 / approx. 20 kg (ANSI 150 4)
 Insertion length of 3.6 m: approx. 17 kg (JIS 5K 65)
 / approx. 22 kg (ANSI 150 4)
 Insertion length of 4.2 m: approx. 19 kg (JIS 5K 65)
 / approx. 24 kg (ANSI 150 4)
 Insertion length of 4.8 m: approx. 21 kg (JIS 5K 65)
 / approx. 26 kg (ANSI 150 4)
 Insertion length of 5.4 m: approx. 23 kg (JIS 5K 65)
 / approx. 28 kg (ANSI 150 4)

2. ZR802G Zirconia Oxygen/Humidity Analyzer, Converter

Display: LCD color display of size 320 by 240 dot
 with touchscreen

Analog Output:

Number of points; Two points (input-output
 isolation)

Output signal;

- 4 to 20 mA DC linear or log can be selected (maximum loadresistance 550 Ω)
- HART7 Communication (maximum loadresistance 550 Ω)
- Burn out signal according to NAMUR NE43.

Output range;

Oxygen concentration; Any setting
 between 0 to 5 through 0 to 100 vol% O₂
 in 1 vol% O₂, or partial range is available.
 For the log output, the minimum range
 value is fixed at 0.1 vol% O₂.

Output damping; 0 to 255 seconds. Hold/non-hold
 selection, preset value setting possible
 with hold.

Analog Input:

Number of points; one point (for Pressure
 compensated)

Input signal; 4 to 20 mA DC (maximum 40 mA)

- Converter power supply (standard)
 voltage; 16.6 to 25.2 V
- With no power supply (option)

Digital Communication:

HART7; AO1, 250 to 550 Ω

Ethernet (Modbus TCP); 10/100 Mbps, Cable length
 Max.100 m, grounding the shield

RS-485 (Modbus RTU); 115200/38400/9600 bps,
 Cable length Max.600 m (115200
 bps) Max.1200 m (38400/9600 bps)
 grounding the shield

Contact Output:

Number of points; Four points (one is fail-
 safe, normally open)

- For DO-1/DO-2/DO-3, select either one,
 normally energized (normally closed) or
 normally de-energized (normally open)
 status. (Open when power is on.)
- DO-4 is fail-safe. (ON at Fault or Failure
 of NE107 setting), fixed normally
 energized (normally open, closed at
 power-off).

Contact capacity; 30VDC 3A or 250VAC 3 A (load
 resistance)

Function; Fault, High-high alarm, High alarm, Low-
 low alarm, Low alarm, Maintenance,
 Calibration, Range switching answer-
 back, Warm-up, Calibration gas
 pressure decrease (answer-back
 of contact input), Temperature high
 alarm, Blowback start, Flameout gas
 detection (answer-back of contact input),
 Calibration coefficient alarm, Startup
 power stabilization timeout alarm

Contact Input:

Number of points; Two points (No-voltage contact
 input or Transistor contact input)

- On/Off detection;
- No-voltage contact input
Resistivity value 200 Ω or less; closed
Resistivity value 100 k Ω or above; open
 - Transistor contact input
Voltage -1 to +1 VDC; closed,
Voltage value 4.5 to +25 VDC or
above; open

Contact capacity; Off-state leakage current 3 mA or less

Function; Calibration gas pressure decrease alarm, Range switching, External calibration start, Flameout gas detection, (ON: heater shut-off and span calibration gas inflow), Blowback start, Reboot

Automatic Calibration Output: Two points (for dedicated automatic calibration unit ZH40H only)

Environmental condition:

Ambient Temperature; -20 to +55°C

Storage Temperature; -30 to +70°C

Humidity; 10 to 90% RH at 40°C (Non-condensing)

Power Supply Voltage:

Ratings; 100 to 240 V AC

Acceptable range; 85 to 264 V AC

Power Supply Frequency:

Ratings; 50/60 Hz

Acceptable range; 47 to 63 Hz

Power Consumption: Max. 800 VA, approx. 330 VA for ordinary use.

Power supply 100V AC: Max. 160 VA (160 W), approx. 120 VA (approx. 100 W) for ordinary use

Power supply 230 V AC: Max 550 VA (370 W), approx. 260 VA (approx. 100 W)

Maximum Distance between Detector and Converter:

Conductor two-way resistance must be 10 Ω or less (when a 1.25 mm² cable or equivalent is used, 300 m or less.)

Construction: NEMA/CSA TYPE 4X (IP66 equivalent) (with conduit holes completely sealed with a cable gland)

Wiring Connection: eight holes

Type; G1/2, M20 \times 1.5mm, Pg13.5, 1/2NPT

Installation: Panel, wall or 2-inch pipe mounting

Material:

Case; Aluminum alloy

Window; Polycarbonate

Paint Color: Silver gray (Munsell 3.2PB7.4/1.2)

Finish: Polyurethane corrosion-resistance coating

Weight: Approx. 5 kg

Functions

Display Functions:

Value Display; Displays values of the measured oxygen concentration, etc

Graph Display; Displays trends of measured oxygen concentration and the test result from a cell resistance tester.

Data Display; Displays various useful data for maintenance, such as cell temperature, reference junction temperature, maximum/minimum oxygen concentration, or the like

Status Message; Indicates an alarm or error occurrence by flashing of the corresponding icon. Indicates status such as warming-up, calibrating, or the like by the marks.

Alarm Display; Alarm name, description, Countermeasures display at error occurrence, NAMUR NE107 compliant 4-symbol display

Calibration Functions:

Calibration method; Zero/span calibration (Either zero or span can be skipped)

Calibration mode;

- Automatic Calibration; Requires the ZR40H Automatic Calibration Unit. It calibrates automatically at specified intervals.

- Semi-automatic Calibration; Requires the ZR40H Automatic Calibration Unit. Input calibration direction on the touchscreen or contact, then it calibrates automatically afterwards.

- Manual Calibration; Calibration with opening/closing the valve of calibration gas in operation interactively with an LCD touchscreen.

Calibration gas setting;

- Zero calibration gas concentration setting range; 0.3 to 100 vol% O₂ (minimum setting; 0.01 vol% O₂)

- Span calibration gas concentration setting range; 4.5 to 100 vol% O₂ (minimum setting; 0.01 vol% O₂)

Use N₂-balanced mixed gas containing 0 to 10% scale of oxygen, and 80 to 100 % scale of oxygen for standard zero gas and standard span gas respectively.

Calibration interval; date/time setting (Max. 255 days)

Purging Function: Before warming up the detector, feed the span gas for the set period of time to drain condensed water out of the piping of calibration gas. Detector's warming-up starts after the set period of purging time elapses.

Blowback Function: To allow a periodic purging etc., open/close contact output in the set period of interval or time defined full/semi-automatically.

Fault:

Alarm Function; The occurrence of Fault alarm stops the power supply to the heater. Fault alarm keeps turning on until the power shuts down.

Type; Cell voltage failure, Heater temperature failure, A/D converter failure, Memory failure, Hardware error, data redundancy mismatch

Alarm:

Function; Alarm keeps turning on until potential causes of a problem are eliminated.

Type; Oxygen concentration alarm, Zero-point calibration coefficient alarm, Span-point calibration coefficient alarm, EMF stabilization time-up alarm, Cold junction temperature alarm, Thermocouple voltage alarm, Input current alarm, Battery low alarm, Input-pressure alarm, Cell resistance alarm

NAMUR NE 107 Alarm Display Function: Displays 4 warnings of NAMUR NE 107 standard;
 F: Failure (Fault equivalent, Power supply to the heater shuts down.)
 C: Function Check
 S: Out of Specification
 M: Maintenance Required

Data Logging Function: Stores following data to SD card or visualizes on the instrument display. SD cards which are recommended or equivalent must be supplied by customer,

Event display; Log of Alarms, Calibration Trend, Power-on history are displayed on the main unit.

Graph Display; Displays trends of test result of resistivity from a cell resistance tester

SD card output; Measurement log (date/time, oxygen concentration, cell e.m.f, test result from a cell resistance tester, cell condition, NE107 status, etc.) Maintenance report (setup value, calibration value etc.) can be saved to SD cards in CSV format. The stored data can be copied to other converter by outputting user-setting parameters to SD cards.

Sensor Self-diagnosis Function:
 Calibration mode diagnose; Span/Zero compensation rate, cell response time, cell condition
 Cell resistance test ; result from a cell resistance test without feeding calibration gas

- Measurement mode; auto cell resistance test, semi-auto cell resistance test,
- Cell resistance test setting; stabilization time (min. sec.) starting time (year/month/date/hour/minute) measurement interval (day/time)

Display and setting content:
 Measuring Related Items: Oxygen concentration (vol% O₂), output current value
 Display Items: Cell temperature (°C), thermocouple reference junction temperature (°C), maximum/minimum/average oxygen concentration (vol% O₂), cell e.m.f. (mV), cell internal resistance (Ω), cell condition (in four grades), heater on-time rate (%), calibration record (twenty times), time (year/month/day, hour/minute)

Calibration Setting Items: Span gas concentration (vol% O₂), zero gas concentration (vol% O₂), calibration mode (automatic, semi-automatic, manual), calibration type and method (zero-span calibration, zero calibration only, span calibration only), stabilization time (min. sec), calibration time (min. sec), calibration interval (day/hour), starting time (year/month/day, hour/minute)

Output Related Items: Analog output/output mode selection, output conditions when warming-up/maintenance/calibrating (during blowback)/abnormal, oxygen concentration at 4 mA/20 mA (vol% O₂), time constant.

Alarm Related Items: Oxygen concentration high alarm/ high-high alarm limit values (vol% O₂), oxygen concentration low alarm/ low-low alarm limit values (vol% O₂), oxygen concentration alarm hysteresis (vol% O₂), oxygen concentration alarm detection, alarm delay (seconds)

Contact Related Items: Selection of contact input 1 and 2, selection of contact output 1 to 3 (Fault, high-high alarm, high alarm, low alarm, low-low alarm, maintenance, calibrating, range switching, warming-up, calibration gas pressure decrease, temperature high alarm, temperature high alarm, pressure high alarm, pressure low alarm, test result from a cell resistance tester, alarm of a cell resistance tester, calibration coefficient alarm, cell e.m.f. stabilization time over blowback, flameout gas detection)

3. ZR202G Integrated type Zirconia Oxygen/ Humidity Analyzer

Display: 6-digit LCD
 Switch: Three optical switches
 Output Signal: 4 to 20 mA DC, one point (maximum load resistance 550 Ω)
 Digital Communication (HART): 250 to 550 Ω, depending on number of field devices connected to the loop (multi-drop mode).
 Contact Output Signal: Two points (one is fail-safe, normally open)
 Contact Input Signal: Two points
 Sample Gas Temperature: 0 to 700°C
 It is necessary to mount the cell using inconel cell-bolts when the temperature is greater than 600°C.
 High temperature service - greater than 700°C - is not available.

Sample Gas Pressure: - 5 to + 250 kPa (When the pressure in the furnace exceeds 3 kPa, it is recommended to use pressure compensated type. When the pressure in the furnace exceeds 5 kPa, pressure compensated type is required.)
 No pressure fluctuation in the furnace should be allowed.

Note: When the detector is used in conjunction with a check valve and the ZA8F Flow Setting Unit, the maximum pressure of sample gas is 150 kPa. When with a check valve and the ZR20H Automatic Calibration Unit, it is 200 kPa. If the pressure of your sample gas exceeds these limits, consult with Yokogawa.

Probe Length: 0.4, 0.7, 1.0, 1.5, 2.0, 2.5, 3.0 m
 Probe Material: JIS SUS316 stainless steel
 Ambient Temperature: -20 to +55°C (case surface temperature is less than +70°C)
 Storage Temperature: -30 to +70°C
 Ambient Humidity: 0 to 95 %RH (non-condensing)
 Power Supply Voltage: Ratings; 100 to 240 V AC
 Acceptable range; 85 to 264 V AC
 Power Supply Frequency: Ratings; 50/60 Hz
 Acceptable range; 45 to 66 Hz
 Power Consumption: Max. 300 W, approx. 100 W for ordinary use.
 Reference Gas System: Natural Convection, Instrument Air, or Pressure Compensated

Instrument Air System (excluding Natural Convection): Pressure; 200 kPa plus the pressure inside the furnace (It is recommended to use air which is dehumidified by cooling to dew point -20°C or less, and dust or oil mist are removed.)
Consumption; Approx. 1 NI/min

Wetted Material: SUS316 (JIS), Zirconia, SUS304 (JIS) or ASTM grade 304 (flange), Hastelloy B, (Inconel 600, 601)

Construction: Heater and thermocouple replaceable construction. Non explosion proof JIS C0920 / equivalent to IP44D. Equivalent to NEMA 4X/IP66 (Achieved when the cable entry is completely sealed with a cable gland in the recirculation pressure compensated version.)

Gas Connection: Rc1/4 or 1/4 NPT(Female)
Wiring Connection: G1/2, Pg 13.5, M20 × 1.5, 1/2 NPT select one type (4 pieces)

Installation: Flange mounting
Probe Mounting Angle: Horizontal to vertically downward. When the probe insertion length is 2 m or less, installing at angles from horizontal to vertical downward is available.
When the probe insertion length is 2.5 m or more, mount vertically downward (within ± 5°) and use a probe protector.

Case: Aluminum alloy
Paint Color: Cover; Mint green (Munsell 5.6BG3.3/2.9)
Case; Mint green (Munsell 5.6BG3.3/2.9)

Finish: Polyurethane corrosion-resistance coating

Weight:
Insertion length of 0.4 m: approx. 8 kg (JIS 5K 65) / approx. 13 kg (ANSI 150 4)
Insertion length of 1.0 m: approx. 10 kg (JIS 5K 65) / approx. 15 kg (ANSI 150 4)
Insertion length of 1.5 m: approx. 12 kg (JIS 5K 65) / approx. 17 kg (ANSI 150 4)
Insertion length of 2.0 m: approx. 14 kg (JIS 5K 65) / approx. 19 kg (ANSI 150 4)
Insertion length of 3.0 m: approx. 17 kg (JIS 5K 65) / approx. 22 kg (ANSI 150 4)

Functions

Display Function: Displays values of the measured oxygen concentration, etc.

Alarm, Error Display: Displays alarms such as "AL-06" or errors such as "Err -01" when any such status occurs.

Calibration Functions:
Automatic Calibration; Requires the ZR20H Automatic Calibration Unit. It calibrates automatically at specified intervals.
Semi-automatic Calibration; Requires the ZR20H Automatic Calibration Unit. Input calibration start signal by optical switch or contact, then it calibrates automatically afterwards.
Manual Calibration; Calibration with opening/closing the valve of calibration gas in operation interactively with the optical switch.

Maintenance Functions:

Can operate updated data settings in daily operation and checking. Display data settings, calibration data settings, test settings (current output loop check, input/output contact check).

Setup Functions:

Initial settings suit for the plant conditions when installing the converter. Current output data settings, alarm data settings, contact data settings, other settings.

Display and setting content:

Display Related Items: Oxygen concentration (vol% O₂), output current value (mA), air ratio, moisture quantity (in hot gases) (vol% H₂O), Cell temperature (°C), thermocouple reference junction temperature (°C), maximum/minimum/average oxygen concentration (vol% O₂), cell e.m.f. (mV), cell internal resistance (Ω), cell condition (in four grades), heater on-time rate (%), calibration record (ten times), time (year/month/day/hour/minute)

Calibration Setting Items: Span gas concentration (vol% O₂), zero gas concentration (vol% O₂), calibration mode (automatic, semi-automatic, manual), calibration type and method (zero-span calibration, zero calibration only, span calibration only), stabilization time (min.sec), calibration time (min.sec), calibration interval (day/hour), starting time (year/month/day/hour/minute)

Output Related Items: Analog output/output mode selection, output conditions when warming-up/maintenance/calibrating/abnormal, oxygen concentration at 4 mA/20 mA (vol% O₂), time constant, preset values when warming-up/maintenance/calibrating/abnormal, output preset values on abnormal

Alarm Related Items: Oxygen concentration high alarm/ high-high alarm limit values (vol% O₂), oxygen concentration low alarm/ low-low alarm limit values (vol% O₂), oxygen concentration alarm hysteresis (vol% O₂), oxygen concentration alarm detection, alarm delay (seconds)

Contact Related Items: Selection of contact input 1 and 2, selection of contact output 1 and 2 (abnormal, high-high alarm, high alarm, low alarm, low-low alarm, maintenance, calibrating, range switching, warming-up, calibration gas pressure decrease, flameout gas detection (answer-back of contact input)

Converter Output: One mA analog output point (4 to 20 mA DC (maximum load resistance of 550 Ω)) with mA digital output point (HART) (minimum load resistance of 250 Ω).

Range: Any setting between 0 to 5 through 0 to 100 vol% O₂ in 1 vol% O₂, and partial range is available (Maximum range value/ minimum range value 1.3 or more)
For the log output, the minimum range value is fixed at 0.1 vol% O₂.
4 to 20 mA DC linear or log can be selected. Input/output isolation.

Output damping; 0 to 255 seconds. Hold/non-hold selection, preset value setting possible with hold.

Contact Output: Two points, contact capacity 30 V DC 3 A, 250 V AC 3 A (resistive load)
One of the output points can be selected to either normally energized or normally de-energized status.
Delayed functions (0 to 255 seconds) and hysteresis function (0 to 9.9 vol% O₂) can be added to high/low alarms.
The following functions are programmable for contact outputs.

- (1) Abnormal, (2) High-high alarm,
- (3) High alarm, (4) Low-low alarm,
- (5) Low alarm, (6) Maintenance,
- (7) Calibration,
- (8) Range switching answer-back,
- (9) Warmup,
- (10) Calibration-gas pressure decrease (answer-back of contact input),
- (11) Flameout gas detection (answer-back of contact input).

Contact Input: Two points, voltage-free contacts
The following functions are programmable for contact inputs.

- (1) Calibration gas pressure decrease alarm,
- (2) Range switching (switched range is fixed),
- (3) External calibration start,
- (4) Process alarm (if this signal is received, the heater power turns off)

Self-diagnosis: Abnormal cell, abnormal cell temperature (low/high), abnormal calibration, defective A/D converter, defective digital circuit

Calibration: Method; Zero/span calibration
Calibration mode; Automatic, semi-automatic and manual (All are operated using optical switches). Either zero or span can be skipped.

Zero calibration gas concentration setting range; 0.3 to 100 vol% O₂ (minimum setting: 0.01 vol% O₂).

Span calibration gas concentration setting range; 4.5 to 100 vol% O₂ (minimum setting: 0.01 vol% O₂).

Use N₂-balanced mixed gas containing 0 to 10% scale of oxygen for standard zero gas, and 80 to 100% scale of oxygen for standard span gas.

Calibration interval; date/time setting: maximum 255 days

■ STANDARD SPECIFICATIONS (High Temperature Humidity Analyzer)

Examples of Application

Separate/Integrated type Zirconia High Temperature Humidity Analyzer

- Coloring processes in the textile industry
- Steam curing processes for concrete products
- Manufacturing processes in the cigarette, food, paper or pulp industries
- Drying processes in various manufacturing of building materials, lumber, plasterboard, food or the like
- Humidifying processes in various manufacturing of food or the like

Please contact us for other applications.

General Specifications

Measurement Object: Water vapor (in vol%) in mixed gases (air and water vapor)

Measurement System: Zirconia system

Measurement Range: 0.01 to 100 vol% O₂, 0 to 100 vol% H₂O or 0 to 1.000 kg/kg

Output Signal: 4 to 20 mA DC (maximum load resistance 550 Ω)

Setting Range: Any setting in the range
Oxygen; 0 to 5 through 0 to 100 vol% O₂ (in 1 vol% O₂), or partial range.

Moisture quantity; 0 to 25 through 0 to 100 vol% H₂O (in 1 vol% H₂O), or partial range.

Mixture ratio; 0 to 0.2 through 0 to 1.000 kg/kg (in 0.001 kg/kg), or partial range.

Display Range: Oxygen concentration; 0 to 100 vol% O₂,
Moisture quantity; 0 to 100 vol% H₂O
Mixture ratio; 0 to 1 kg/kg
Relative humidity; 0 to 100%RH (Note)
Dew point; -40 to 164°C (Note)

(Note): These values are affected by temperature and absolute pressure. So accurate temperature and pressure values must be inputted to the converter.

Warming-up Time: Approx. 20 min.

Repeatability: (Excluding the case where the reference gas is by natural convection)
±1 vol% H₂O; Sample gas pressure 2 kPa or less

Linearity: (Excluding standard gas tolerance and the case where the reference gas is by natural convection)

(Use oxygen of known concentration (in the measuring range) as the zero and span calibration gas.)

± 2 vol% H₂O; Sample gas pressure: within ± 0.49 kPa

± 3 vol% H₂O; Sample gas pressure: 2 kPa or less

Drift: (Excluding the first two weeks in use and the case where the reference gas is by natural convection.)

Both zero and span ± 3 vol% H₂O/month

Response Time: Response of 90% within 5 seconds.
(Measured after gas is introduced from calibration gas inlet and analog output starts changing.)

Safety, EMC, and RoHS conformity standards of ZR22G, ZR802G and ZR202G

Installation altitude: 2000 m or less

Installation category: (IEC61010); II

Pollution degree: (IEC61010); 2

- Note · Installation category, called overvoltage category, specifies impulse withstanding voltage. Category II is for electrical equipment.
 · Pollution degree indicates the degree of existence of solid, liquid, gas or other inclusions which reduce dielectric strength. Degree 2 is the normal indoor environment.

Safety:

ZR202G/ZR22G;

CE	EN 61010-1 EN 61010-2-030
UL	UL61010-1:2nd Edition
CSA	CAN/CSA-C22.2 No. 61010-1
GB	GB30439 Part 1

ZR802G;

CE	EN 61010-1/A1 EN 61010-2-030
UL	UL61010-1:3rd Edition, AMD1 UL61010-2-030:1st Edition
CSA	CAN/CSA-C22.2 No. 61010-1+Amd1 CAN/CSA-C22.2 No. 61010-2-030
GB	GB30439 Part 1

EMC:

CE	EN 61326-1 Class A Table 2 EN 61326-2-3, EN 61000-3-2
----	---

RCM	EN 55011 Class A, Group 1
KC	KN11 Class A Group1, KN61000-6-2

- Note · This instrument is a Class A product, and it is designed for use in the industrial environment. Please use this instrument in the industrial environment only.
 · Influence of immunity environment (Criteria A) : Output shift is specified within $\pm 20\%$ of F.S.

RoHS: EN IEC 63000

Others:

REACH Regulation EC 1907/2006
 Information of the WEEE Directive
 This product is purposely designed to be used in a large scale fixed installations only and, therefore, is out of scope of the WEEE Directive. The WEEE Directive is only valid in the EU.

1. ZR22G Zirconia Oxygen/Humidity Analyzer, Detector

Sample Gas Temperature: 0 to 700°C (Probe only)
 It is recommended to mount the cell using inconel cell-bolts when the temperature is greater than 600°C.

Sample Gas Pressure: - 5 to + 20 kPa (When the pressure in the furnace exceeds 3 kPa, it is recommended to use pressure compensated type. When the pressure in the furnace exceeds 5 kPa, pressure compensated type is required.)
 No pressure fluctuation in the process should be allowed.

Probe Length: 0.4, 0.7, 1.0, 1.5, 2.0, 2.5, 3.0 m

Probe Material: SUS316

Ambient Temperature: -20 to +150°C

Reference Gas System: Natural Convection, Instrument Air System (excluding Natural Convection) It is recommended to use air which has been dehumidified by cooling to dew point -20°C or less, and dust or oil mist are removed.

Supply gas pressure; Sample Gas pressure:
 +approx. 50 kPa

Sample gas pressure + approx. 150 kPa (/CV: with check valve)

Wetted Material: SUS316, Zirconia, SUS304 or ASTM grade 304 (flange), Hastelloy B, (Inconel 600, 601)

Construction: Heater and thermocouple replaceable construction. Non explosion proof JIS C0920 / equivalent to IP44D. Equivalent to NEMA 4X/IP66 (Achieved when the cable entry is completely sealed with a cable gland in the recirculation pressure compensated version.)

Terminal Box Case: Material; Aluminum alloy

Terminal Box Paint Color:

Case and Cover; Mint green (Munsell 5.6BG3.3/2.9)

Finish: Polyurethane corrosion-resistance coating

Gas Connection: Rc1/4 or 1/4 NPT (Female)

Wiring Connection: G1/2, Pg 13.5, M20 × 1.5, 1/2 NPT

Installation: Flange mounting

Probe Mounting Angle: Horizontal to vertically downward. When the probe insertion length is 2 m or less, installing at angles from horizontal to vertically downward is available.

When the probe insertion length exceeds 2.5 m, mount vertically downward (within $\pm 5^\circ$) and use a probe protector.

Weight:

Insertion length of 0.4 m: approx. 6 kg (JIS 5K 65) / approx. 11 kg (ANSI 150 4)

Insertion length of 1.0 m: approx. 8 kg (JIS 5K 65) / approx. 13 kg (ANSI 150 4)

Insertion length of 1.5 m: approx. 10 kg (JIS 5K 65) / approx. 15 kg (ANSI 150 4)

Insertion length of 2.0 m: approx. 12 kg (JIS 5K 65) / approx. 17 kg (ANSI 150 4)

Insertion length of 3.0 m: approx. 15 kg (JIS 5K 65) / approx. 20 kg (ANSI 150 4)

2. ZR802G Zirconia Oxygen/Humidity Analyzer, Converter

Display: LCD color display of size 320 by 240 dot with touchscreen.

Analog Output:

Number of points; Two points (input-output isolation)

Out put signal;

- 4 to 20 mA DC linear or log can be selected (maximum loadresistance 550 Ω)
- HART7 Communication (maximum loadresistance 550 Ω)
- Burn out signal according to NAMUR NE43.

Out put range; Any setting between

- Oxygen concentration; 0 to 5 through 0 to 100 vol%O₂ in 1 vol%O₂, or partial range is available.
- Moisture quantity; 0 to 25 through 0 to 100 vol%H₂O, or partial range is available.
- Mixture ratio; 0 to 0.200 through 0 to 1.000 kg/kg, or partial range is available.

- Relative humidity; 0 to 5 through 0 to 100 vol%RH in 1 vol%RH, or partial range is available.
 - For the log output, the minimum range value is fixed at 0.1 vol%O₂.
 - Out put damping; 0 to 255 seconds. Hold/non-hold selection, preset value setting possible with hold.
 - Analog Input: Number of points; one point (thermal input)
 - Input signal; 4 to 20 mA DC (2-wire input, input resistance 250 Ω)
 - Converter power supply (standard) voltage; 16.6 to 25.2 V
 - With no power supply (option)
 - Digital Communication
 - HART7; AO1, 250 to 550 Ω
 - Ethernet (Modbus TCP); 10/100 Mbps, Cable length Max.100 m, grounding the shield
 - RS-485 (Modbus RTU); 115200/38400/9600 bps, Cable length Max.600 m (115200 bps) Max.1200 m (38400/9600 bps) grounding the shield
 - Contact Output:
 - Number of points; Four points (one is fail-safe, normally open)
 - For DO-1/DO-2/DO-3, select either one, normally energized (normally closed) or normally de-energized (normally open) status. (Open when power is on.)
 - DO-4 is fail-safe. (ON at Fault or Failure of NE107 setting), fixed normally energized (normally open, closed at power-off).
 - Contact capacity; 30VDC 3A or 250VAC 3 A (load resistance)
 - Function; Fault, High-high alarm, High alarm, Low-low alarm, Low alarm, Maintenance, Calibration, Range switching answer-back, Warm-up, Calibration gas pressure decrease (answer-back of contact input), Temperature high alarm, Blowback start, Flameout gas detection (answer-back of contact input), Calibration coefficient alarm, Startup power stabilization timeout alarm
 - Contact Input:
 - Number of points; Two points (No-voltage contact input or Transistor contact input)
 - On/Off detection;
 - No-voltage contact input
Resistivity value 200 Ω or less; closed
Resistivity value 100 k Ω or above; open
 - Transistor contact input
Voltage -1 to +1 VDC; closed,
Voltage value 4.5 to +25 VDC or above; open
 - Contact capacity; Off-state leakage current 3 mA or less
 - Function; Calibration gas pressure decrease alarm, Range switching, External calibration start, Flameout gas detection, (ON: heater shut-off and span calibration gas inflow), Blowback start, Reboot
 - Automatic Calibration Output: Two points (for dedicated automatic calibration unit ZR40H only)
 - Environmental condition:
 - Ambient Temperature; -20 to +55°C
 - Storage Temperature; -30 to +70°C
 - Humidity; 10 to 90% RH at 40°C(Non-condensing)
 - Power Supply Voltage: Ratings; 100 to 240 V AC
Acceptable range; 85 to 264 V AC
 - Power Supply Frequency: Ratings; 50/60 Hz
Acceptable range; 47 to 63 Hz
 - Power Consumption: Max. 800 VA, approx. 330 VA for ordinary use.
Power supply 100V AC: Max. 160 VA (160 W), approx. 120 VA (approx. 100 W) for ordinary use
Power supply 230 V AC: Max 550 VA (370 W), approx. 260 VA (approx. 100 W) for ordinary use
 - Maximum Distance between Detector and Converter: Conductor two-way resistance must be 10 Ω or less (when a 1.25 mm² cable or equivalent is used, 300 m or less.)
 - Construction: NEMA/CSA TYPE 4X (IP66 equivalent) (with conduit holes completely sealed with a cable gland)
 - Wiring Connection: eight holes
Type: G1/2, M20 × 1.5mm, Pg13.5, 1/2NPT
Installation: Panel, wall or 2-inch pipe mounting
Material:
 - Case: Aluminum alloy
 - Window: Polycarbonate
 - Paint Color:
 - Door and Case; Silver gray (Munsell 3.2PB7.4/1.2)
 - Finish: Polyurethane corrosion-resistance coating
 - Weight: Approx. 5 kg
- ### Functions
- Value Display; Displays values of the measured oxygen concentration, etc
 - Graph Display; Displays trends of measured oxygen concentration and the test result from a cell resistance tester.
 - Data Display; Displays various useful data for maintenance, such as cell temperature, reference junction temperature, maximum/minimum oxygen concentration, or the like
 - Status Message; Indicates an alarm or error occurrence by flashing of the corresponding icon. Indicates status such as warming-up, calibrating, or the like by the marks.
 - Alarm Display; Alarm name, description, Countermeasures display at error occurrence, NAMUR NE107 compliant 4-symbol display
 - Calibration Functions:
 - Calibration method; Zero/span calibration (Either zero or span can be skipped)
 - Calibration mode;
 - Automatic Calibration; Requires the ZR40H Automatic Calibration Unit. It calibrates automatically at specified intervals.
 - Semi-automatic Calibration; Requires the ZR40H Automatic Calibration Unit. Input calibration direction on the touchscreen or contact, then it calibrates automatically afterwards.
 - Manual Calibration; Calibration with opening/closing the valve of calibration gas in operation interactively with an LCD touchscreen.

- Calibration gas setting;
- Zero calibration gas concentration setting range; 0.3 to 100 vol% O₂ (minimum setting; 0.01 vol% O₂)
 - Span calibration gas concentration setting range; 4.5 to 100 vol% O₂ (minimum setting; 0.01 vol% O₂)
- Use N₂-balanced mixed gas containing 0 to 10% scale of oxygen for standard zero gas, and 80 to 100% scale of oxygen for standard span gas.
- Calibration interval; date/time setting (maximum 255 days)
- Purging function: Before warming up the detector, feed the span gas for the set period of time to drain condensed water out of the piping of calibration gas. Detector's warming-up starts after the set period of purging time elapses.
- Blowback Function: To allow a periodic purging etc., open/close contact output in the set period of interval or time defined full/semi-automatically.
- Alarm Function:
- Fault:
- Function; The occurrence of Fault alarm stops the power supply to the heater. Fault alarm keeps turning on until the power shuts down.
- Type; Cell voltage failure, Heater temperature failure, A/D converter failure, Memory failure, Hardware error, data redundancy mismatch
- Alarm:
- Function; Alarm keeps turning on until potential causes of a problem are eliminated.
- Type; Oxygen concentration alarm, Humidity alarm, Mixing-ratio alarm, relative humidity alarm, Zero-point calibration coefficient alarm, Span-point calibration coefficient alarm, EMF stabilization time-up alarm, Input-temperature alarm, Cold junction temperature alarm, Thermocouple voltage alarm, Input current alarm, Battery low alarm, Cell resistance alarm
- NAMUR NE 107 Alarm Display Function:
- Displays 4 warnings of NAMUR NE 107 standard;
- F: Failure (Fault equivalent, Power supply to the heater shuts down.)
- C: Function Check
- S: Out of Specification
- M: Maintenance Required
- Data Logging Function: Stores following data to SD card or visualizes on the instrument display.
- SD cards which are recommended or equivalent must be supplied by customers,
- Event; Log of Alarms, Calibration Trend; Log of test result from a cell resistance test in a trend graph
 - Graph Display; Displays trends of test result of resistivity from a cell resistance tester
- Measurement log saved to SD card (date/time, oxygen concentration, cell e.m.f, test result from a cell resistance tester, cell condition, NE107 status, etc.) Maintenance report (setup value, calibration value etc.) can be saved to SD cards in CSV format. The stored data can be copied to other converter by outputting the data of user-setting parameters to SD cards.
 - Data logging cycle ; selectable, 1 sec. X 8 (days), 2 sec. x 16 (days), 5 sec. x 40 (days)
- Sensor Self-diagnosis Function:
- Calibration mode:
- Calibration mode diagnose; Span/Zero compensation rate, cell response time, cell condition
- Cell resistance test ; result from a cell resistance test without feeding calibration gas
- Measurement mode; auto cell resistance test, semi-auto cell resistance test,
 - Cell resistance test setting; stabilization time (min. sec.) starting time (year/month/date/hour/minute) measurement interval (day/time) .
- Display and setting content:**
- Measuring Related Items: Oxygen concentration (vol% O₂), moisture quantity (vol% H₂O), mixture ratio (kg/kg), relative humidity (%RH) and dew point (°C)
- Display Items: Oxygen concentration (vol% O₂), moisture quantity (vol% H₂O), mixture ratio (kg/kg), relative humidity (%RH), dew point (°C), cell temperature (°C), thermocouple reference junction temperature (°C), maximum/minimum/average oxygen concentration (vol% O₂), maximum/ minimum/average moisture quantity (vol% H₂O), maximum/ minimum/average mixture ratio (kg/ kg), cell e.m.f. (mV), output 1, 2 current (mA), cell response time (seconds), cell internal resistance (Ω), cell condition (in four grades), heater on-time rate (%), calibration record (twenty times), time (year/month/day, hour/minute)
- Calibration Setting Items: Span gas concentration (vol% O₂), zero gas concentration (vol% O₂), calibration mode (automatic, semi-automatic, manual), calibration type and method (zero-span calibration, zero calibration only, span calibration only), stabilization time (min.sec), calibration time (min.sec), calibration interval (day/ hour), starting time (year/month/day, hour/minute)
- Output Related Items: Analog output/output mode selection, output conditions when warmingup/maintenance/calibrating/ abnormal, oxygen concentration at 4 mA/20 mA (vol% O₂), moisture quantity at 4 mA/20 mA (vol% H₂O), mixture ratio at 4 mA/20 mA (kg/ kg), time constant.

Alarm Related Items: Oxygen concentration high alarm/ high-high alarm limit values (vol% O₂), oxygen concentration low alarm/ low-low alarm limit values (vol% O₂), moisture quantity high alarm/high-high alarm limit values (vol% H₂O), moisture quantity low alarm/ low-low alarm limit values (vol% H₂O), mixture ratio high alarm/high-high alarm limit value (kg/ kg), mixture ratio low alarm/low-low alarm limit values (kg/ kg), oxygen concentration alarm hysteresis (vol% O₂), moisture quantity alarm hysteresis (vol% H₂O), mixture ratio alarm hysteresis (kg/ kg), oxygen concentration/moisture quantity/mixture ratio alarm detection, alarm delay (seconds).

Contact Related Items: Selection of contact input 1 and 2, selection of contact output 1 to 3 (Fault, high-high alarm, high alarm, low alarm, low-low alarm, maintenance, calibrating, range switching, warming-up, calibration gas pressure decrease, temperature high alarm, temperature low alarm, pressure high alarm, pressure low alarm, test result from a cell resistance tester, alarm of a cell resistance tester, calibration coefficient alarm, cell e.m.f. stabilization time over, blowback, flameout gas detection

3. ZR202G Integrated type Zirconia Oxygen/ Humidity Analyzer

Can be operated in the field without opening the cover using optical switches.

Display: 6-digit LCD
 Switch: Three optical switches
 Output Signal: 4 to 20 mA DC, one point (maximum load resistance 550 Ω)
 Digital Communication (HART): 250 to 550 Ω, depending on number of field devices connected to the loop (multi-drop mode).
 Contact Output Signal: Two points (one is fail-safe, normally open)
 Contact Input Signal: Two points
 Sample Gas Temperature: 0 to 700°C
 It is necessary to mount the cell using inconel cell-bolts when the temperature than 600°C.

Sample Gas Pressure: - 5 to + 20 kPa (When the pressure in the furnace exceeds 3 kPa, it is recommended to use pressure compensated type. When the pressure in the furnace exceeds 5 kPa, pressure compensated type is required.)
 No pressure fluctuation in the process should be allowed.

Probe Length: 0.4, 0.7, 1.0, 1.5, 2.0, 2.5, 3.0 m
 Probe Material: JIS SUS316 stainless steel
 Ambient Temperature: -20 to +55°C (case surface temperature is less than +70°C)
 Storage Temperature: -30 to +70°C
 Ambient Humidity: 0 to 95%RH (non - condensing)
 Power Supply Voltage: Ratings; 100 to 240 V AC
 Acceptable range; 85 to 264 V AC
 Power Supply Frequency: Ratings; 50/60 Hz
 Acceptable range; 45 to 66 Hz

Power Consumption: Max. 300 W, approx. 100 W for ordinary use.

Reference Gas System: Natural Convection, Instrument Air, or Pressure Compensated Instrument Air System (excluding Natural Convection): Pressure; 200 kPa plus the pressure inside the process (It is recommended to use air which is dehumidified by cooling to dew point -20°C or less, and dust or oil mist are removed.)

Consumption; Approx. 1 NI/min

Wetted Material SUS316 (JIS), Zirconia, SUS304 (JIS) or ASTM grade 304 (flange), Hastelloy B, (Inconel 600, 601)

Construction: Heater and thermocouple replaceable construction. Non explosion-proof JIS C0920 / equivalent to IP44D. Equivalent to NEMA 4X/IP66 (Achieved when the cable entry is completely sealed with a cable gland in the recirculation pressure compensated version.)

Gas Connection: Rc1/4 or 1/4 NPT (Female)

Wiring Connection: G1/2, Pg 13.5, M20 × 1.5, 1/2 NPT select one type (4 pieces)

Installation: Flange mounting

Probe Mounting Angle: Horizontal to vertically downward. When the probe insertion length is 2 m or less, installing at angles from horizontal to vertically downward is available.

When the probe insertion length is 2.5 m or more, mount vertically downward (within ± 5°) and use a probe protector.

Case: Aluminum alloy

Paint Color:

Cover and Case; Mint green (Munsell 5.6BG3.3/2.9)

Finish: Polyurethane corrosion-resistance coating

Weight:

Insertion length of 0.4 m: approx. 8 kg (JIS 5K 65) / approx. 13 kg (ANSI 150 4)

Insertion length of 1.0 m: approx. 10 kg (JIS 5K 65) / approx. 15 kg (ANSI 150 4)

Insertion length of 1.5 m: approx. 12 kg (JIS 5K 65) / approx. 17 kg (ANSI 150 4)

Insertion length of 2.0 m: approx. 14 kg (JIS 5K 65) / approx. 19 kg (ANSI 150 4)

Insertion length of 3.0 m: approx. 17 kg (JIS 5K 65) / approx. 22 kg (ANSI 150 4)

Functions

Display Function: Displays values of the measured oxygen concentration, moisture quantity, mixture ratio etc

Alarm, Error Display: Displays alarms such as "AL-06" or errors such as "Err-01" when any such status occurs.

Calibration Functions:

Automatic Calibration; Requires the ZR20H Automatic Calibration Unit. It calibrates automatically at specified intervals.

Semi-automatic Calibration; Requires the ZR20H Automatic Calibration Unit. Input calibration start signal by optical switch or contact, then it calibrates automatically afterwards.

<p>Manual Calibration; Calibration with opening/closing the valve of calibration gas in operation interactively with the optical switch.</p>	<p>Contact Related Items: Selection of contact input 1 and 2, selection of contact output 1 and 2 (abnormal, high-high alarm, high alarm, low alarm, low-low alarm, maintenance, calibrating, range switching, warming-up, calibration gas pressure decrease, flameout gas detection)</p>
<p>Maintenance Functions: Can operate updated data settings in daily operation and checking. Display data settings, calibration data settings, test settings (current output loop check, input/output contact check).</p>	<p>Converter Output: One mA analog output point (4 to 20 mA DC (maximum load resistance of 550 Ω)) with mA digital output point (HART) (minimum load resistance of 250 Ω).</p>
<p>Setup Functions: Initial settings suit for the plant conditions when installing the converter. Current output data settings, alarm data settings, contact data settings, other settings.</p>	<p>Range; Any setting between 0 to 25 through 0 to 100 vol% H₂O, and partial range is available (Maximum range value/minimum range value 1.3 or more) For the log output, the minimum range values are fixed to 0.1 vol% O₂ for the oxygen concentration, 0.1 vol% H₂O for the moisture quantity, and 0.01 kg/kg for the mixture ratio.</p>
<p>Display and setting content: Display Related Items: Oxygen concentration (vol% O₂), moisture quantity (vol% H₂O), mixture ratio(kg/kg), relative humidity(%RH), dew point (°C), cell temperature (°C), thermocouple reference junction temperature (°C), maximum/minimum/average oxygen concentration (vol% O₂), maximum/minimum/average moisture quantity (vol% H₂O), maximum/minimum/average mixture ratio (kg/kg), cell e.m.f. (mV), output 1, 2 current (mA), cell response time (seconds), cell internal resistance (Ω), cell condition (in four grades), heater on-time rate (%), calibration record (ten times), time (year/month/day/hour/minute)</p>	<p>4 to 20 mA DC linear or log can be selected. Input/output isolation</p> <p>Output damping; 0 to 255 seconds. Hold/non-hold selection, preset value setting possible with hold.</p> <p>Contact Output: Two points, contact capacity 30 V DC 3 A, 250 V AC 3 A (resistive load) Normally energized or normally de-energized can be selected. Delayed functions (0 to 255 seconds) and hysteresis function (0 to 9.9 vol% O₂) can be added to high/low alarms. The following functions are programmable for contact outputs.</p>
<p>Calibration Setting Items: Span gas concentration (vol% O₂), zero gas concentration (vol% O₂), calibration mode (automatic, semi-automatic, manual), calibration type and method (zero-span calibration, zero calibration only, span calibration only), stabilization time (min.sec), calibration time (min.sec), calibration interval (day/hour), starting time (year/month/day/hour/minute)</p>	<p>(1) Abnormal, (2) High-high alarm, (3) Highalarm, (4) Low-low alarm, (5) Low alarm, (6) Maintenance, (7) Calibration, (8) Range switching answer-back, (9) Warming-up, (10) Calibration gas pressure decrease (answer-back of contact input), (11) Flameout gas detection (answer-back of contact input).</p>
<p>Output Related Items: Analog output/output mode selection, output conditions when warming-up/ maintenance/calibrating/ abnormal, oxygen concentration at 4 mA/ 20 mA (vol% O₂), moisture quantity at 4 mA/ 20 mA (vol% H₂O), mixture ratio at 4 mA/ 20 mA (kg/kg), time constant, preset values when warming-up/maintenance/calibrating/abnormal, output preset values on abnormal</p>	<p>Contact Input: Two points, voltage-free contacts The following functions are programmable for contact inputs.</p> <p>(1) Calibration-gas pressure decrease alarm, (2) Range switching (switched range is fixed), (3) External calibration start, (4) Process alarm (if this signal is received, the heater power turns off)</p>
<p>Alarm Related Items: Oxygen concentration high alarm/ high-high alarm limit values (vol% O₂), oxygen concentration low alarm/low-low alarm limit values (vol% O₂), moisture quantity high alarm/high-high alarm limit values (vol% H₂O), moisture quantity low alarm/ low-low alarm limit values (vol% H₂O), mixture ratio high alarm/high-high alarm limit values (kg/kg), mixture ratio low alarm/low-low alarm limit values (kg/kg), oxygen concentration alarm hysteresis (vol% O₂), moisture quantity alarm hysteresis (vol% H₂O), mixture ratio alarm hysteresis (kg/kg), oxygen concentration/moisture quantity/ mixture ratio detection, alarm delay (seconds)</p>	<p>Contact capacity: Off-leakage current; 3 mA or less. Self-diagnosis: Abnormal cell, abnormal cell temperature (low/high), abnormal calibration, defective A/D converter, defective digital circuit</p> <p>Calibration: Method; Zero/span calibration Calibration mode; automatic, semi-automatic and manual (All are operated using optical switches). Either zero or span can be skipped.</p> <p>Zero calibration gas concentration setting range; 0.3 to 100 vol% O₂ (minimum setting: 0.01 vol% O₂).</p>

Span calibration gas concentration setting range;
4.5 to 100 vol% O₂ (minimum setting:
0.01 vol% O₂).
Use N₂-balanced mixed gas containing 0
to 10% scale of oxygen for standard zero
gas, and 80 to 100% scale of oxygen for
standard span gas.
Calibration interval; date/time setting:
maximum 255 days

■ OPTIONS

4. ZO21P High Temperature Probe Adapter for Oxygen Analyzer

Measuring O₂ in the high temperature gases (exceeds 700°C) requires a general-use probe ZR22G of 0.15 m length and a high temperature probe adapter.

Sample gas temperature: 0 to 1400°C (when using SiC probe)
0 to 800°C (when using SUS310S probe adapter)

Sample gas pressure: -0.5 to +5 kPa. When using in the range of 0 to 25 vol% O₂ or more, the sample gas pressure should be in the range of -0.5 to +0.5 kPa. (Where the sample gas pressure for the high-temperature probe is negative, an ejector assembly is necessary.)

Insertion length: 0.5, 0.6, 0.7, 0.8, 0.9, 1.0, 1.5 m
Material in Contact with Gas: SUS316 (JIS), SiC or SUS310S, SUS304 (JIS) or ASTM grade 304 (flange)

Probe Material: SiC, SUS310S (JIS)
Installation: Flange mounting (FF type or RF type)
Probe Mounting Angle: Vertically downward within ± 5°. Where the probe material is SUS310S, horizontal mounting is available.

Construction: Non explosion-proof. Rainproof construction

Weight(example): Insertion length of 1.0 m: approx. 5.3 kg (JIS) / approx. 11.3 kg (ANSI)
Insertion length of 1.5 m: approx. 5.8 kg (JIS) / approx. 11.8 kg (ANSI)

5. E7046EC/E7046EN Ejector Assembly for High Temperature Probe of Oxygen Analyzer

For use in cases where pressure of sample gas for high temperature detector is negative.

5.1 Needle Valve

Connection: Rc1/4 or 1/4 NPT (Female)

Material: SUS316 (JIS)

Note: Pipes and connectors are not provided.

5.2 Pressure Gauge Assembly

Material in Contact with Gas: SUS316 (JIS)
Case Material: Aluminum alloy (Paint color; black)
Scale: 0 to 100 kPa G
Connection: R1/4 or 1/4 NPT, SUS304 (JIS)
(with Bushing G3/8 x R1/4 or 1/4 NPT (Female))

5.3 Ejector

Ejector Inlet Air Pressure: 29 to 68 kPa G
Air Consumption: Approx. 30 to 40 l/min
Suction gas flow rate: 3 to 7 l/min
Connection: Rc1/4, SUS304 (JIS)
Tube Connection: (Ø6/Ø4 mm or 1/4 inch copper tube or stainless tube)

6. ZO21R Probe Protector for Oxygen Analyzer

Used when sample gas flow velocity is approx. 10m/sec or more and dust particles wears the detector in cases such as pulverized coal boiler of fluidized bed furnace (or burner) to protect the detector from wearing by dust particles. When probe insertion length is 2.5 m or more and horizontal installation, specify the ZO21R-L-200-□*B to reinforce the probe.

Insertion Length: 1.05, 1.55, 2.05 m.

Flange: JIS 5K 65A FF equivalent. ANSI Class 150 4 FF (without serration) equivalent. However, flange thickness is different.

Material: SUS316 (JIS), SUS304 (JIS) or ASTM grade 304 (Flange)

Weight: 1.05 m; Approx. 6/10/8.5 kg (JIS/ANSI), 1.55 m; Approx. 9/13/11.5 kg (JIS/ANSI), 2.05 m; Approx. 12/16/14.5 kg (JIS/ANSI)

Installation: Bolts, nuts, and washers are provided for detector, probe adapter and process-side flange.

7. K9471UA/K9471UX Dust Filter for Zirconia Oxygen Analyzers

This filter is used to protect the cell from corrosive dust components or high velocity dust in recovery boilers and cement kiln. Sample gas flow rate is needed to be 1m/sec or more to replace gas inside zirconia sensor.

Mesh: 30 microns

Material: SiC (Filter), SUS316 (JIS)

Weight: Approx. 0.2 kg

8. K9471UC Dust Guard Protector for Oxygen Analyzer

Recommended to be used when sample gas is likely to flow directly into the cell due to its flow direction in the stack or the like, flammable dust may go into the cell, or water drops are likely to fall and remain in the cell during downtime or the like due to the installation position.

Material: SUS316 (JIS)

Weight: Approx. 0.3 kg

9. ZH21B Dust Protector for Humidity Analyzer

This protector is designed to protect the probe output from dust agitation (i.e., to prevent combustible materials from entering the probe cell) where humidity measurements are made under dusty environments.

Insertion length: 0.440 m

Flange: JIS 5K 80 FF equivalent or ANSI Class150 4 FF equivalent. (However, flange thickness is different.)

Material: SiC, SUS316 (JIS), SUS304 (JIS) or ASTM grade 304 (flange)

Weight: Approx. 6 kg (JIS), approx. 8.5 kg (ANSI)

Mounting: Mounted on the probe or process flange withbolts and the associated nuts and washers.

10. ZO21S Standard Gas Unit

The ZO21S does not conform to CE marking.

Function: Portable unit for calibration gas supply consisting of span gas (air) pump, zero gas cylinder with sealed inlet, flow rate checker and flow rate needle valve.

Sealed Zero Gas Cylinders (6 provided): E7050BA
Capacity: 1 l

Filled pressure: Approx. 686 kPa G (at 35°C)

Composition: 0.95 to 1.0 vol% O₂ (N₂-balanced)

Power Supply: 100, 110, 115, 200, 220, 240V AC
± 10%, 50/60 Hz

Power Consumption: Max. 5 VA

Paint Color:

Mainframe; Munsell 2.0 GY3.1/0.5 equivalent

Cover; Munsell 2.8 GY6.4/0.9 equivalent

Weight: Approx. 3 kg

11. ZA8F Flow Setting Unit for manual calibration

Used when instrument air is provided.

This unit consists of flowmeter and flow control valve to controls flow rates of calibration gas and reference gas.

Flowmeter Scale: Calibration gas; 0.1 to 1.0 l/min.
Reference gas; 0.1 to 1.0 l/min.

Construction: Dust-proof and rainproof construction

Case Material: SPCC (Cold rolled steel sheet)

Painting: Baked epoxy resin, Dark-green (Munsell 2.0 GY 3.1/0.5 or equivalent)

Tube Connections: Rc1/4 or 1/4 NPT (Female)

Reference Gas Pressure: Clean air supply of sample gas pressure plus approx. 50 kPa G (or sample gas pressure plus approx. 150 kPa when a check valve is used.) Pressure at inlet of the flow setting unit. (Max. 300 kPa G)

Air Consumption: Approx. 1.5 l/min

Weight: Approx. 2.3 kg

12. ZR40H Automatic Calibration Unit for ZR802G

Used when automatic calibration is required for the separate type and instrument air is provided. The solenoid valves are provided as standard.

Construction: Dust-proof and rainproof construction:
NEMA 4X/IP67 - only for case coating
solenoid valve, not flowmeter (excluding flowmeter)

Mounting: 2-inch pipe or wall mounting, no vibration

Materials: Body: Aluminum alloy, Piping: SUS316 (JIS), SUS304 (JIS), Flowmeter: MA (Methacrylate resin) Bracket : SUS304 (JIS)

Finish: Polyurethane corrosion-resistance coating, Mint green (Munsell 5.6BG3.3/2.9)

Piping Connection: Rc1/4 or 1/4 NPT (Female)

Power Supply: 24V DC (from ZR402G), Power consumption: Approx. 1.3 W

Reference Gas Pressure: Sample gas pressure plus Approx. 150 kPa (690 kPa max.), (Pressure at inlet of automatic calibration unit)

Air Consumption: Approx. 1.5 l/min

Weight: Approx. 3.5 kg

Ambient Temperature: -20 to +55°C, no condensing and freezing

Ambient Humidity: 0 to 95%RH

Storage Temperature: -30 to +65°C

13. ZR20H Automatic Calibration Unit for ZR202G

Used when automatic calibration is specified for the integrated type and instrument air is provided.

Equipped with the analyzer when automatic calibration is specified in the suffix code of the ZR202G Integrated type by selecting either "-A (Horizontal mounting)" or "-B (Vertical mounting)". The ZR20H should be arranged when automatic calibration is to be required after the ZR202H has been installed. Ask Yokogawa service station for its mounting.

Construction: Dust-proof and rainproof construction;
NEMA 4X/IP67 (excluding flowmeter)

Mounting: Mounted on ZR202G, no vibration

Materials: Body: Aluminum alloy, Piping: SUS316 (JIS), SUS304 (JIS), Flowmeter: MA (Methacrylate resin)

Finish: Polyurethane corrosion-resistance coating

Case: Mint green (Munsell 5.6BG3.3/2.9),

Cover: Mint green (Munsell 5.6BG3.3/2.9)

Piping Connection: Rc1/4 or 1/4 NPT(Female)

Power Supply: 24V DC (from ZR202G), Power consumption: 1.3 W

Reference Gas Pressure: Sample gas pressure plus Approx. 150 kPa (690 kPa max.), (Pressure at inlet of automatic calibration unit)

Air Consumption: Approx. 1.5 l/min

Weight: Approx. 2 kg

Ambient Temperature: -20 to +55°C, no condensing and freezing

Ambient Humidity: 0 to 95%RH

Storage Temperature: -30 to +65°C

14. L9852CB/G7016XH Stop Valve for Calibration gas line

The stop valve is mounted on the calibration gas line. To include Nipple Stop Valve with the product, select the suffix code (/SV) for ZR22G Separate type Zirconia Oxygen/High Temperature Humidity Analyzer, Detector or ZR202G Integrated type Zirconia Oxygen/High/High Temperature Humidity Analyzer.

Connection: Rc1/4 or 1/4 NPT (Female)

Material: SUS316 (JIS)

Weight: Approx. 150 g

15. K9292DN/K9292DS Check Valve for Calibration gas line

This is used to prevent entry of sample gas into calibration gas line. Purpose is the same as stop valve, but is convenient, as it does not need to be opened or closed for calibration.

Mount directly on calibration gas inlet of detector in place of stop valve. However as source pressure of 150 kPa G or more is needed, standard gas unit cannot be used.

When option code "/CV" of the ZR22G or the ZR202G is specified, check valve is provided.

Connection: Rc1/4 or 1/4 NPT (Female)

Material: SUS304 (JIS)

Pressure: Between 70 kPa G or more 350 kPa G or less

Weight: Approx. 90 g

16. G7003XF/K9473XK, G7004XF/K9473XG Air Set**G7003XF/K9473XK**

Primary Pressure: Max. 1 MPa G
 Secondary Pressure: 0.02 to 0.2 MPa G
 Connection: Rc1/4 or 1/4 NPT (F) with joint adapter

G7004XF/K9473XG

Primary Pressure: Max. 1 MPa G
 Secondary Pressure: 0.02 to 0.5 MPa G
 Connection: Rc1/4 or 1/4 NPT (F) with joint adapter

17. G7001ZC Zero gas Cylinder

Capacity: 3.4 l
 Filled pressure: 9.8 to 12 MPa G
 Composition: 0.95 to 1.0 vol% O₂ (N₂-balanced)
 Note: Export of such high pressure filled gas cylinders to most countries is prohibited or restricted.

18. G7013XF/G7014XF Pressure Regulator for Gas Cylinder

Primary Pressure: Max. 14.8 MPa G,
 Secondary Pressure; 0 to 0.4 MPa G
 Connection: Inlet W22 14 threads, right hand screw
 Outlet Rc1/4 or 1/4 NPT (Female)
 Material: Brass body

19. E7044KF Pressure Regulator for Gas Cylinder

Case Paint: Baked epoxy resin,
 Jade green (Munsell 7.5 BG 4/1.5)
 Installation: 2B pipe mounting
 Weight: Approx. 10 kg
 Note: Export of such high pressure filled gas cylinders to most countries is prohibited or restricted.

20. ZR22A Heater Assembly for ZR22G

Spare Parts for ZR22G Heater Assembly
 Note: Yokogawa shall not guarantee the heater assembly after its replacement.

21. ZR202A Heater Assembly for ZR202G

Spare Parts for ZR202G Heat Assembly
 Note: Yokogawa shall not guarantee the heater assembly after its replacement.

STANDARD ACCESSORIES

ZR22G

Item	Parts. No.	Q'ty	Description
Allen wrench	L9827AB	1	For lock screw

ZR802G

Item	Q'ty	Description
Fuse	1	3.15 A (Parts No. A1113EF)
Bracket	1	For pipe mounting
Screws for Bracket	1	

ZR202G

Item	Parts. No.	Q'ty	Description
Fuse	A1113EF	1	3.15 A
Allen wrench	L9827AB	1	For lock screw

■ Model and Code

1. ZR22G Zirconia Oxygen/Humidity Analyzer, Detector

Style : S2

Model	Suffix code	Option code	Description	
ZR22G	-----	-----	Zirconia Oxygen/Humidity Analyzer, Detector	
Length	-015	-----	0.15 m (for high temperature use) (*1)	
	-040	-----	0.4 m	
	-070	-----	0.7 m	
	-100	-----	1.0 m	
	-150	-----	1.5 m	
	-200	-----	2.0 m	
	-250	-----	2.5 m (*2)	
	-300	-----	3.0 m (*2)	
	-360	-----	3.6 m (*2)	
	-420	-----	4.2 m (*2)	
	-480	-----	4.8 m (*2)	
	-540	-----	5.4 m (*2)	
Wetted material	-S	-----	Stainless steel	
	-C	-----	Stainless steel with Inconel calibration gas tube (*10)	
Flange (*3)	-A	-----	ANSI Class 150 2 RF	
	-B	-----	ANSI Class 150 3 RF	
	-C	-----	ANSI Class 150 4 RF	
	-E	-----	DIN PN10 DN50 A	
	-F	-----	DIN PN10 DN80 A	
	-G	-----	DIN PN10 DN100 A	
	-K	-----	JIS 5K 65 FF	
	-L	-----	JIS 10K 65 FF	
	-M	-----	JIS 10K 80 FF	
	-P	-----	JIS 10K 100 FF	
	-Q	-----	JIS 5K 32 FF (for high temperature use) (*4)	
	-R	-----	JPI Class 150 4 RF	
-S	-----	JPI Class 150 3 RF		
-W	-----	Westinghouse		
Reference gas	-C	-----	Natural convection	
	-E	-----	External connection (Instrument air) (*11)	
	-P	-----	Pressure compensated (*11)	
Gas Thread	-R	-----	Rc1/4	
	-T	-----	1/4NPT(Female)	
Connection box thread	-P	-----	G1/2	
	-G	-----	Pg13.5	
	-M	-----	M20 x1.5	
	-T	-----	1/2 NPT	
	-Q	-----	Quick connect (*9)	
Instruction manual	-J	-----	Japanese	
	-E	-----	English	
	-C	-----	Chinese	
--	-A	-----	Always -A	
Options	/C	-----	Inconel bolt (*5)	
	Valves	/CV	-----	Check valve (*6)
		/SV	-----	Stop valve (*6)
	Filter	/F1	-----	Dust Filter (*7)
		/F2	-----	Dust Guard Protector (*7)
	Tag plates	/SCT	-----	Stainless steel tag plate (*8)
		/PT	-----	Printed tag plate (*8)
	Standard	/EQ	-----	EAC with PA (*12)
/ER		-----	EAC (*12)	

*1 Used with the ZO21P High Temperature Probe Adapter. Select flange (-Q).

*2 When installing horizontally the probe whose insertion length is 2.5 m or more, use the Probe Protector. Be sure to specify ZO21R-L-200-□. Specify the flange suffix code either -C or -K.

*3 The thickness of the flange depends on its dimensions.

*4 Not used in conjunction with —P (pressure compensation) for reference gas. The flange thickness does not conform to JIS specification

*5 Inconel probe bolts and U shape pipe are used. Use this option for high temperature use (ranging from 600 to 700 °C).

*6 Specify either /CV or /SV option code.

*7 Not used with the high temperature humidity analyzer.

*8 Specify either /SCT or /PT option code.

*9 Not waterproof, avoid rain. Operating maximum temperature is 80°C. Available only in the U.S.

*10 Recommended if sample gas contains corrosive gas like chlorine.

*11 Piping for reference gas must be installed to supply reference gas constantly at a specified flow rate.

*12 "/EQ" is EAC with Pattern Approval for Russia. "/ER" is EAC for Kazakhstan and Belarus.

2. ZR802G Zirconia Oxygen/Humidity Analyzer, Converter

Model	Suffix code	Option code	Description
ZR802G	-----	-----	Zirconia Oxygen/Humidity Analyzer, Converter
Converter thread	-P -G -M -T	----- ----- ----- -----	G1/2 Pg 13.5 M20 x 1.5 mm 1/2 NPT
Display communication	-H -M -E	----- ----- -----	HART HART+Modbus RS485 HART+Modbus Ethernet
—	-N	-----	Always -N
—	-N	-----	Always -N
Option		/SCT /H /CJ /AI /RC /BR	Stainless steel tag plate Hood, sun shield hood Cold junction temperature compensation (with Pt1000 resistance thermometer) (*1) Analog input with no power supply Rugged Coating (Epoxy + Urethane Coating) Wall mounting Bracket for ZR402G replacement

(*1) Connect the supplied Pt1000 resistance thermometer for cold junction temperature compensation to CJ terminal, when /CJ is specified.

<Items specified at order>

- High temperature humidity analyzer
When the use for high temperature humidity analyzer is not specified, the product is shipped as an Oxygen Analyzer.
- TAGNO. (only if necessary)
You can create TAGNO. (tag number) with alphanumeric characters described in the next table. 16 characters at maximum can be used. If you specify TAGNO., it is displayed on the instrument screen, and is printed on the stainless name plate/tag label affixed to the instrument.

Symbol (Note)	-	Hyphen	_	Underscore
	=	Equal	+	Plus
	/	Slash	:	Colon
	(Left parenthesis)	Right parenthesis
	#	Hash	!	Exclamation mark
	.	Period		
Number	0, 1, 2, 3, 4, 5, 6, 7, 8, 9			
Upper case alphabets	A, B, C, D, E, F, G, H, I, J, K, L, M, N, O, P, Q, R, S, T, U, V, W, X, Y, Z			
lower case alphabets	a, b, c, d, e, f, g, h, i, j, k, l, m, n, o, p, q, r, s, t, u, v, w, x, y, z			

(Note): The spaces specified for the TAGNO. are removed. The string is left-squeezed.

- Language
English, Chinese, German, French, Portuguese, Japanese

● STANDARD ACCESSORIES

Item	Q'ty	Description
Fuse	1	Parts No. A1113EF
Mounting bracket (standard)	1	(Note 1)
Bolt for mounting bracket	4	M6x10 mm
Washer for mounting bracket	4	for M6
Bolt for pipe mounting	4	M6x70 mm
Screws for pipe mounting	2	M6x100 mm
Tag label (standard)	1	(Note 2)

(Note 1) When /BR or /RC is specified, the included mounting brackets are different from the standard accessories according to the specifications.

(Note 2) Tag label is included when suffix code except for /SCT is specified.
A blank label is included when no TAGNO. is specified.

● SD card (supplied by customer)

Item	Q'ty	Parts No.	Description
SD card	1	773001	1 GB Customer may provide. 128 MB or above SD or SDHC

3. ZR202G Integrated type Zirconia Oxygen/Humidity Analyzer

Model	Suffix code	Option code	Description
ZR202G	-----	-----	Zirconia Oxygen/Humidity Analyzer, Detector
Length	-040 -070 -100 -150 -200 -250 -300	----- ----- ----- ----- ----- ----- -----	0.4 m 0.7 m 1.0 m 1.5 m 2.0 m 2.5 m (*1) 3.0 m (*1)
Wetted material	-S -C	----- -----	Stainless steel Stainless steel with Inconel calibration gas tube (*10)
Flange (*2)	-A -B -C -E -F -G -K -L -M -P -R -S -W	----- ----- ----- ----- ----- ----- ----- ----- ----- ----- ----- ----- -----	ANSI Class 150 2 RF ANSI Class 150 3 RF ANSI Class 150 4 RF DIN PN10 DN50 A DIN PN10 DN80 A DIN PN10 DN100 A JIS 5K 65 FF JIS 10K 65 FF JIS 10K 80 FF JIS 10K 100 FF JPI Class 150 4 RF JPI Class 150 3 RF Westinghouse
Auto Calibration	-N -A -B	----- ----- -----	Not required Horizontal mounting (*8) Vertical mounting (*8)
Reference gas	-C -E -P	----- ----- -----	Natural convection External connection (Instrument air) (*11) Pressure compensated (*11)(*14)
Gas Thread	-R -T	----- -----	Rc1/4 1/4 NPT (Female)
Connection box thread	-P -G -M -T	----- ----- ----- -----	G1/2 Pg 13.5 M20x1.5 1/2 NPT
Instruction manual	-J -E -C	----- ----- -----	Japanese English Chinese
--	-A	-----	Always -A
Options	Valves	/C	Inconel bolt (*3)
		/HS	Set for Humidity Analyzer (*4)
		/CV /SV	Check valve (*5) Stop valve (*5)
	Tag plates	/H	Hood (*9)
		/F1 /F2	Dust Filter (*6) Dust Guard Protector (*6)
	NAMUR NE43 compliant	/SCT /PT	Stainless steel tag plate (*7) Printed tag plate (*7)
		/C2 /C3	Failure alarm down-scale: Output status at CPU failure and hardware error is 3.6 mA or less (*12) Failure alarm up-scale: Output status at CPU failure and hardware error is 21.0 mA or more (*12)
	Standard	/EQ /ER	EAC with PA (*13) EAC (*13)

*1 For the horizontally installed probe whose insertion length is 2.5 m or more, use the Probe Protector. Be sure to specify ZO21R-L-200-□. Specify the flange suffix code either -C or -K.

*2 The thickness of the flange depends on its dimensions.

*3 Inconel probe bolts and U shape pipe are used. Use this option for high temperature use (ranging from 600 to 700°C).

*4 For humidity measurements, be sure to specify /HS options. Pressure compensation of reference gas can not be selected.

*5 Specify either /CV or /SV option code.

*6 Not used with the high temperature humidity analyzer.

*7 Specify either /SCT or /PT option code.

*8 No need to specify the option codes, /CV and /SV, since the check valves are provided with the Automatic Calibration Unit. Automatic calibration cannot be used when natural convection is selected as reference air.

*9 Sun shield hood is still effective even if scratched. Hood is necessary for outdoor installation out of sun shield roof.

*10 Recommended if sample gas contains corrosive gas like chlorine.

*11 Piping for reference gas must be installed to supply reference gas constantly at a specified flow rate.

*12 Output signal limits: 3.8 to 20.5 mA. Specify either /C2 or /C3 option code.

*13 "/EQ" is EAC with Pattern Approval for Russia. "/ER" is EAC for Kazakhstan and Belarus.

*14 When Pressure Compensated is specified with "-A" or "-B" in Auto Calibration, consult with Yokogawa.

4. ZO21P High Temperature Probe Adapter for Oxygen Analyzer

Model	Suffix code	Option code	Description
ZO21P	-H	-----	High Temperature Probe Adapter
Material	-A -B	----- -----	SiC SUS 310S (JIS)
Insertion length	-050 -060 -070 -080 -090 -100 -150	----- ----- ----- ----- ----- ----- -----	0.5 m 0.6 m 0.7 m 0.8 m 0.9 m 1.0 m 1.5 m
Flange	-J -N -M -L -A -R -Q -T -S -E	----- ----- ----- ----- ----- ----- ----- ----- ----- -----	JIS 5K 50 FF JIS 10K 65 FF JIS 10K 80 FF JIS 10K 100 FF ANSI Class 150 4 RF ANSI Class 150 2 1/2 RF ANSI Class 150 3 RF JPI Class 150 3 RF JPI Class 150 4 RF DIN PN10 DN50 A
Style code	*B	-----	Style B
Option	Ejector Tag plate	/EJ1 /EJ2 /SCT	Ejector Assy with E7046EC Ejector Assy with E7046EN Stainless steel tag plate

Note: For this high-temperature use probe adapter, be sure to specify the ZR22G probe of its insertion length 0.15 meters.

High Temperature Probes (Spare Parts)

Part No.	Description
K9292TP	SiC, insertion length 0.5 m
E7046CF	SiC, insertion length 0.6 m
K9292TQ	SiC, insertion length 0.7 m
E7046CG	SiC, insertion length 0.8 m
E7046CH	SiC, insertion length 0.9 m
E7046AL	SiC, insertion length 1.0 m
E7046BB	SiC, insertion length 1.5 m
K9292TV	SUS310S (JIS), insertion length 0.5 m
E7046CR	SUS310S (JIS), insertion length 0.6 m
K9292TW	SUS310S (JIS), insertion length 0.7 m
E7046CS	SUS310S (JIS), insertion length 0.8 m
E7046CT	SUS310S (JIS), insertion length 0.9 m
E7046AP	SUS310S (JIS), insertion length 1.0 m
E7046AQ	SUS310S (JIS), insertion length 1.5 m

5. E7046EC/E7046EN Ejector Assembly for High Temperature Probe of Oxygen Analyzer

Part No.	Description
E7046EC	Needle valve; Rc1/4, Pressure gauge; R1/4, Ejector; $\varnothing 6/\varnothing 4$ mm TUBE joint: SUS304 (JIS)
E7046EN	Needle valve; 1/4 NPT(F), Pressure gauge; 1/4 NPT(M), Ejector; 1/4 TUBE joint: SUS304 (JIS)

6. ZO21R Probe Protector for Oxygen Analyzer

Model	Suffix code	Option code	Description
ZO21R	-L	-----	Probe Protector (0 to 700°C)
Insertion length	-100 -150 -200	----- ----- -----	1.05 m 1.55 m 2.05 m
Flange (*1)	-J -A	----- -----	JIS 5K 65 FF ANSI Class 150 4 FF
Style code	*B	-----	Style B

*1 Thickness of flange depends on dimensions of flange.

7. K9471UA Dust Filter for Oxygen Analyzer

Part No.	Description
K9471UA	Filter
K9471UX	Tool

8. K9471UC Dust Guard Protector for Oxygen Analyzer

Part No.	Description
K9471UC	Dust guard protector

9. ZH21B Dust Protector for Humidity Analyzer

Model	Suffix code	Option code	Description
ZH21B	-----	-----	Dust Protector (0 to 600°C)
Insertion length	-040	-----	0.428 m
Flange	-J -A	----- -----	JIS 5K 80 FF *(1) ANSI Class 150 4B FF *(2)
Style code	*B	-----	Style B

* The flange thickness varies.

Specify the probe ZR22G-040-□-K or ZR202G-040-□-K in case of (1)
ZR22G-040-□-C or ZR202G-040-□-C in case of (2)

10. ZO21S Standard Gas Unit

Model	Suffix code	Option code	Description
ZO21S	-----	-----	Standard gas unit
Power supply	-2	-----	200 V AC 50/60 Hz
	-3	-----	220 V AC 50/60 Hz
	-4	-----	240 V AC 50/60 Hz
	-5	-----	100 V AC 50/60 Hz
	-7	-----	110 V AC 50/60 Hz
	-8	-----	115 V AC 50/60 Hz
Panel	-J	-----	Japanese version
	-E	-----	English version
Style code	*A	-----	Style A

11. ZA8F Flow Setting Unit for manual calibration

Model	Suffix code	Option code	Description
ZA8F	-----	-----	Flow setting unit
Joint	-J	-----	Rc1/4
	-A	-----	With 1/4 NPT (F) adapter
Style code	*C	-----	Style C

12. ZR40H Automatic Calibration Unit for ZR802G

Model	Suffix code	Option code	Description
ZR40H	-----	-----	Automatic calibration unit for ZR802G
Gas piping connection	-R	-----	Rc1/4
	-T	-----	1/4 NPT (F)
Wiring connection	-P	-----	G1/2
	-G	-----	Pg 13.5
	-M	-----	M20 x 1.5
	-T	-----	1/2 NPT
--	-A	-----	Always -A

13. ZR20H Automatic Calibration Unit for ZR202G

Model	Suffix code	Option code	Description
ZR20H	-----	-----	Automatic calibration unit for ZR202G *1
Gas piping connection	-R	-----	Rc1/4
	-T	-----	1/4 NPT (F)
Reference air *2	-E	-----	Instrument air
	-P	-----	Pressure compensated
Mounting	-A	-----	Horizontal mounting
	-B	-----	Vertical mounting
-	-A	-----	Always -A

*1 Ask Yokogawa service station for additional mounting of ZR20H to the preinstalled ZR202G.

*2 Select the appropriate reference gas of ZR20H according to the one of ZR202G.

14. L9852CB/G7016XH Stop Valve for Calibration gas line

Part No.	Description
L9852CB	Joint: Rc1/4, Material: SUS316 (JIS)
G7016XH	Joint: 1/4 NPT (F), Material: SUS316 (JIS)

15. K9292DN/K9292DS Check Valve for Calibration gas line

Part No.	Description
K9292DN	Joint: Rc1/4, Material: SUS304 (JIS)
K9292DS	Joint: 1/4 NPT (F), Material: SUS304 (JIS)

16. G7003XF/K9473XK, G7004XF/K9473XG Air Set

Part No.	Description
G7003XF	Joint: Rc1/4, Material: Zinc alloy
K9473XK	Joint: 1/4 NPT (F), Material: Zinc alloy with adapter
G7004XF	Joint: Rc1/4, Material: Zinc alloy
K9473XG	Joint: 1/4 NPT (F), Material: Zinc alloy with adapter

17. G7001ZC Zero gas Cylinder

Part No.	Description
G7001ZC	3.4 l container, 0.95 to 1.0 vol % O ₂ , N ₂ -balanced.

Note: Export of such high pressure filled gas cylinders to most countries is prohibited or restricted.

18. G7013XF/G7014XF Pressure Regulator for Gas Cylinder

Part No.	Description
G7013XF	Inlet: W22 14 threads, Outlet: Rc1/4
G7014XF	Inlet: W22 14 threads, Outlet: 1/4 NPT (F)

19. E7044KF Case Assembly for Calibration-gas Cylinder

Part No.	Description
E7044KF	Calibration gas unit case

Note: Export of such high pressure filled gas cylinders to most countries is prohibited or restricted.

20. ZR22A, ZR202A Heater Assembly

Style: S2

Model		Option code	Description
ZR22A	-----	-----	Heater Assembly for ZR22G
Length (*1)	-015	-----	0.15 m
	-040	-----	0.4 m
	-070	-----	0.7 m
	-100	-----	1 m
	-150	-----	1.5 m
	-200	-----	2 m
	-250	-----	2.5 m
	-300	-----	3 m
Jig for change	-A	-----	with Jig (*2)
	-N	-----	None
Reference gas (*3)	-A	-----	Natural convection, External connection (Instrument air)
	-B	-----	Pressure compensated (for ZR22G S2)
	-C	-----	Pressure compensated (for ZR22G S1)

*1 Suffix code of length should be selected as same as ZR22G installed.

*2 Jig part no. is K9470BX to order as a parts after purchase.

*3 Select appropriately among "-A", "-B", "-C" according to the reference gas supply method and style.

Note: The heater is made of ceramic, do not drop or subject it to pressure stress.

Model	Suffix code	Option code	Description
ZR202A	-----	-----	Heater Assembly for ZR202G
Length (*1)	-040	-----	0.4 m
	-070	-----	0.7 m
	-100	-----	1 m
	-150	-----	1.5 m
	-200	-----	2 m
	-250	-----	2.5 m
	-300	-----	3 m
	Jig for change	-A	-----
-N		-----	None
—	-A	-----	Always -A

*1 Suffix code of length should be selected as same as ZR202G installed.

*2 Jig part no. is K9470BX to order as a parts after purchase.

Note: The heater is made of ceramic, do not drop or subject it to pressure stress.

EXTERNAL DIMENSIONS

1. ZR22G Zirconia Oxygen/Humidity Analyzer, Detector

Unit : mm

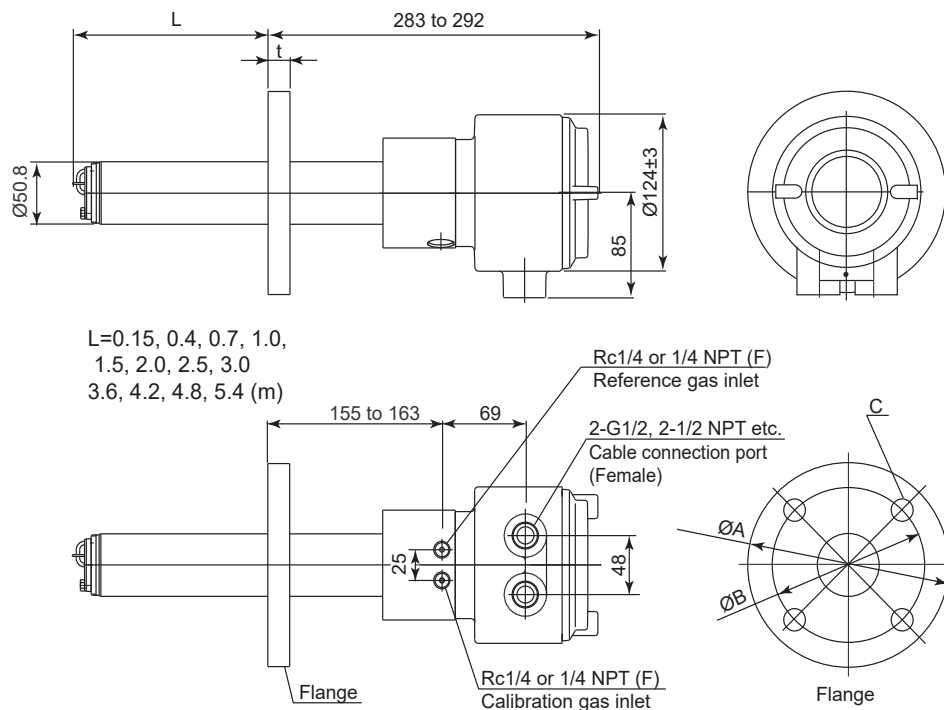

Flange	A	B	C	t
ANSI Class 150 2 RF	152.4	120.6	4 - Ø19	19
ANSI Class 150 3 RF	190.5	152.4	4 - Ø19	24
ANSI Class 150 4 RF	228.6	190.5	8 - Ø19	24
DIN PN10 DN50 A	165	125	4 - Ø18	18
DIN PN10 DN80 A	200	160	8 - Ø18	20
DIN PN10 DN100 A	220	180	8 - Ø18	20
JIS 5K 65 FF	155	130	4 - Ø15	14
JIS 10K 65 FF	175	140	4 - Ø19	18
JIS 10K 80 FF	185	150	8 - Ø19	18
JIS 10K 100 FF	210	175	8 - Ø19	18
JIS 5K 32 FF	115	90	4 - Ø15	5
JPI Class 150 4 RF	229	190.5	8 - Ø19	24
JPI Class 150 3 RF	190	152.4	4 - Ø19	24
Westinghouse	155	127	4 - Ø11.5	14

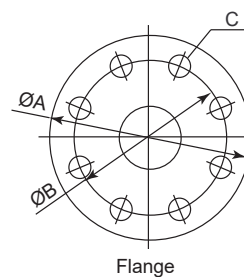

ZR22G...-P (with pressure compensated) Zirconia Oxygen/Humidity Analyzer, Detector

Unit : mm

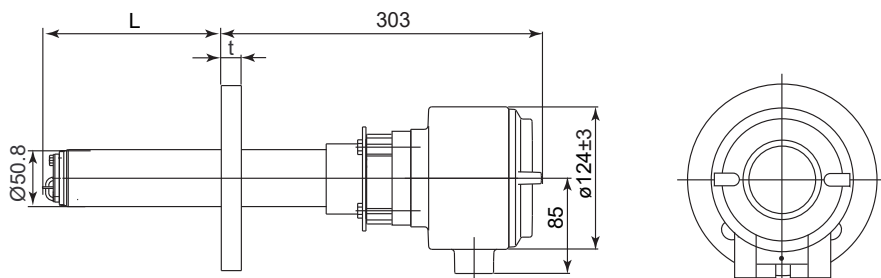

L=0.15, 0.4, 0.7, 1.0,
1.5, 2.0, 2.5, 3.0
3.6, 4.2, 4.8, 5.4 (m)

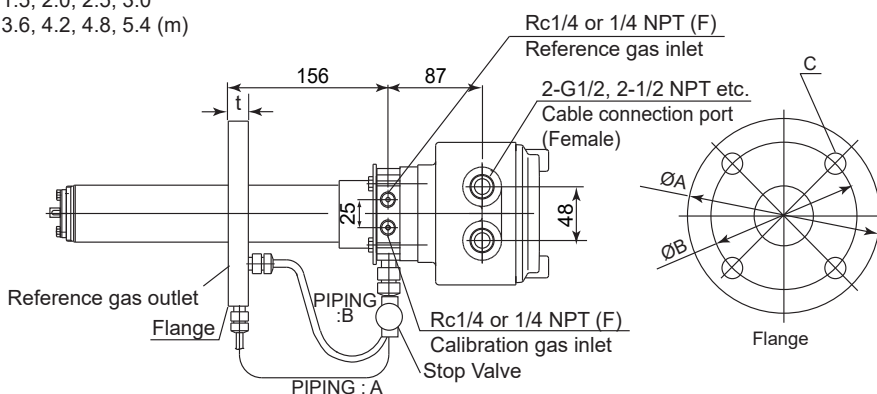

Flange	A	B	C	t	PIPING
ANSI Class 150 2 RF	152.4	120.6	4 - Ø19	19	A
ANSI Class 150 3 RF	190.5	152.4	4 - Ø19	24	B
ANSI Class 150 4 RF	228.6	190.5	8 - Ø19	24	B
DIN PN10 DN50 A	165	125	4 - Ø18	18	A
DIN PN10 DN80 A	200	160	8 - Ø18	20	B
DIN PN10 DN100 A	220	180	8 - Ø18	20	B
JIS 5K 65 FF	155	130	4 - Ø15	14	A
JIS 10K 65 FF	175	140	4 - Ø19	18	A
JIS 10K 80 FF	185	150	8 - Ø19	18	B
JIS 10K 100 FF	210	175	8 - Ø19	18	B
JPI Class 150 4 RF	229	190.5	8 - Ø19	24	B
JPI Class 150 3 RF	190	152.4	4 - Ø19	24	B
Westinghouse	155	127	4 - Ø11.5	14	A

● Check Valve (option code /CV), Stop valve (option code /SV) -specified Calibration gas inlet

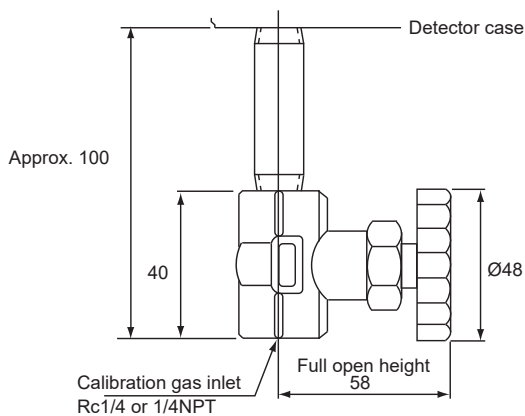

with Stop Valve (option: /SV)

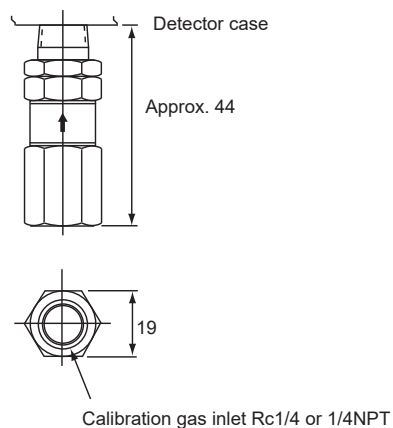

with Check Valve (option: /CV)

2. ZR802G Zirconia Oxygen/Humidity Analyzer, Converter

Unit: mm

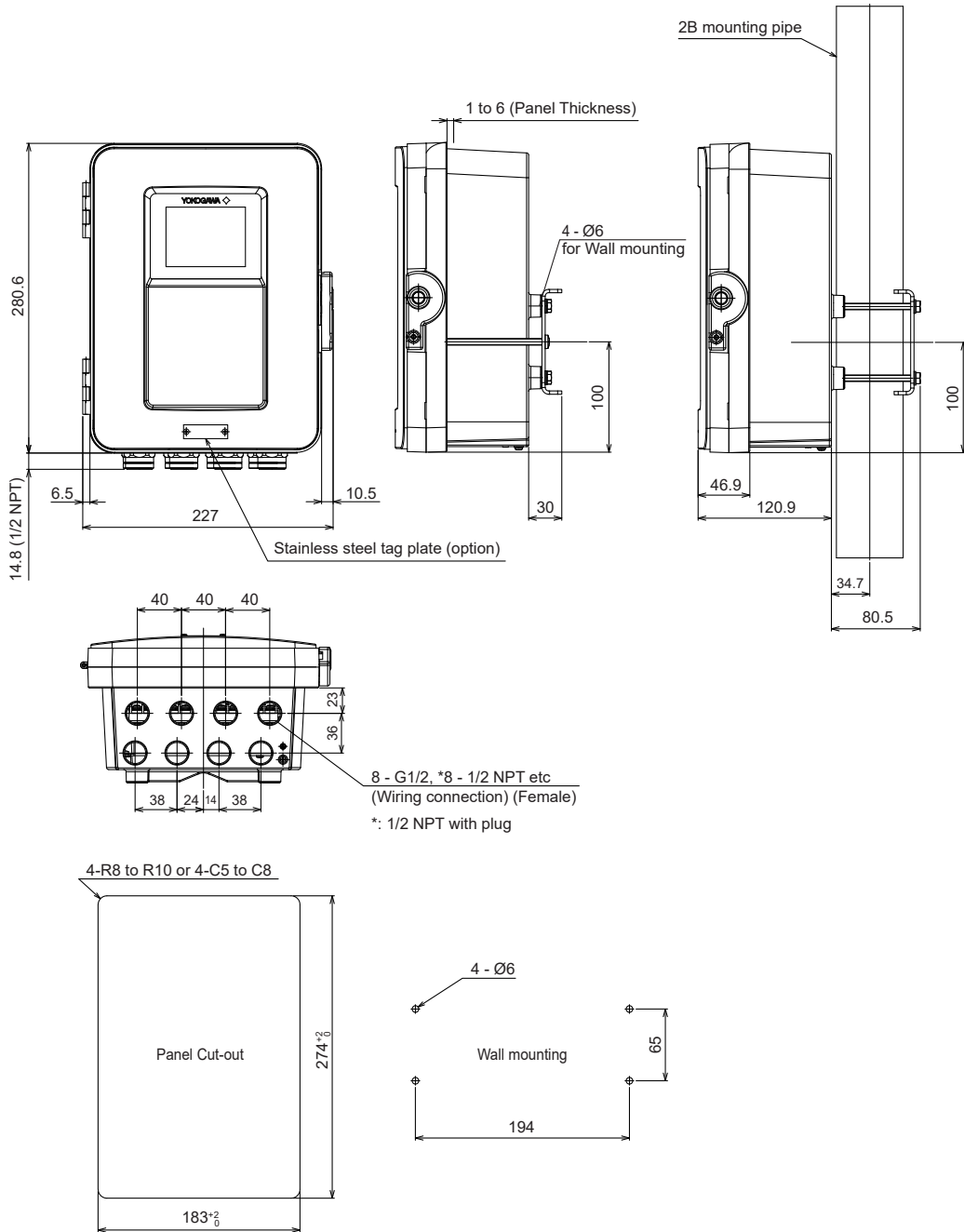

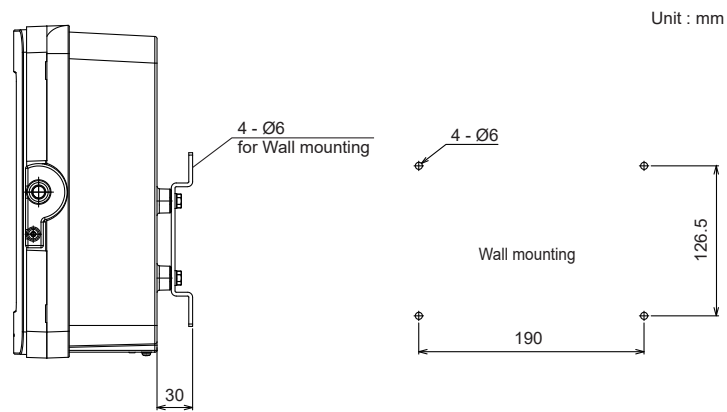
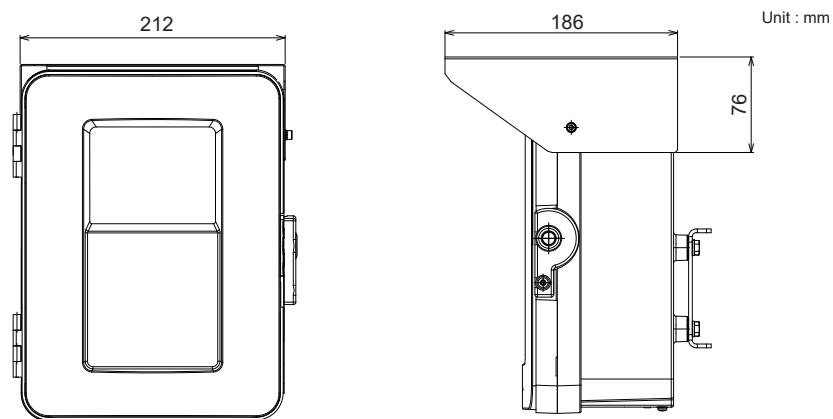
● With Replacement Bracket (option code /BR, ZR402G replacement Wall mounting Bracket)**● With sun shield hood (option code /H)**

3. ZR202G Integrated type Zirconia Oxygen/Humidity Analyzer

Unit: mm

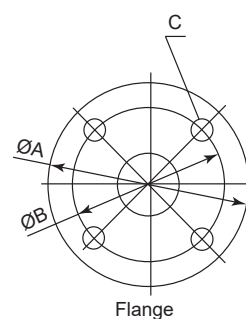
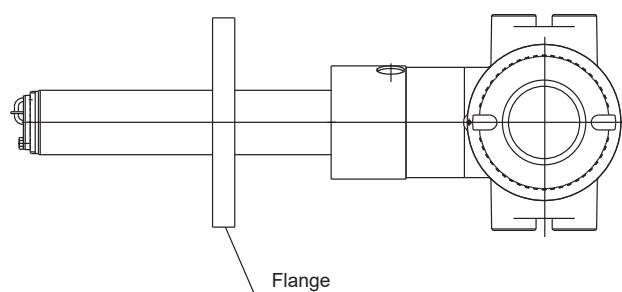
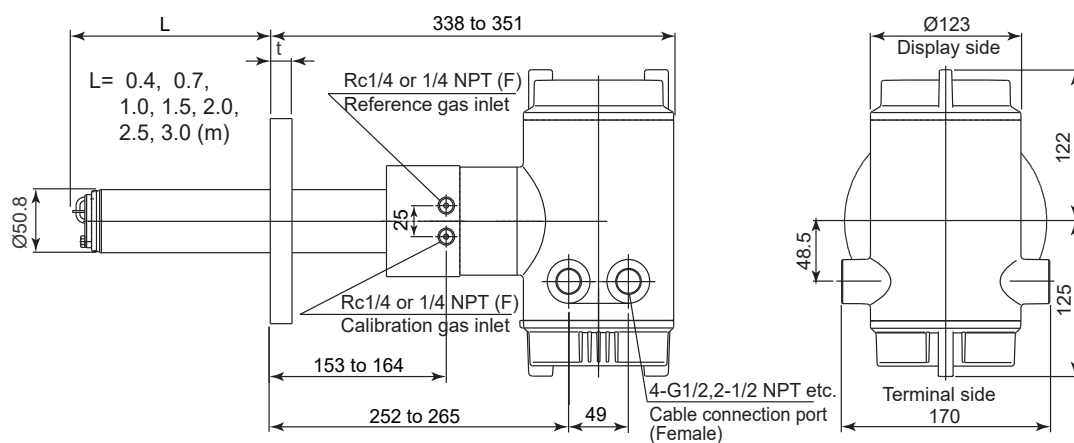

Flange	A	B	C	t
ANSI Class 150 2 RF	152.4	120.6	4 - $\text{Ø}19$	19
ANSI Class 150 3 RF	190.5	152.4	4 - $\text{Ø}19$	24
ANSI Class 150 4 RF	228.6	190.5	8 - $\text{Ø}19$	24
DIN PN10 DN50 A	165	125	4 - $\text{Ø}18$	18
DIN PN10 DN80 A	200	160	8 - $\text{Ø}18$	20
DIN PN10 DN100 A	220	180	8 - $\text{Ø}18$	20
JIS 5K 65 FF	155	130	4 - $\text{Ø}15$	14
JIS 10K 65 FF	175	140	4 - $\text{Ø}19$	18
JIS 10K 80 FF	185	150	8 - $\text{Ø}19$	18
JIS 10K 100 FF	210	175	8 - $\text{Ø}19$	18
JPI Class 150 4 RF	229	190.5	8 - $\text{Ø}19$	24
JPI Class 150 3 RF	190	152.4	4 - $\text{Ø}19$	24
Westinghouse	155	127	4 - $\text{Ø}11.5$	14

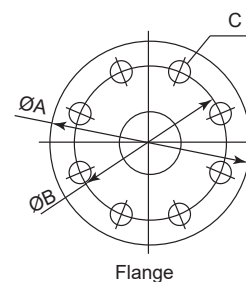

ZR202G...-P (with pressure compensated) Zirconia Oxygen/Humidity Analyzer, Detector

Unit: mm

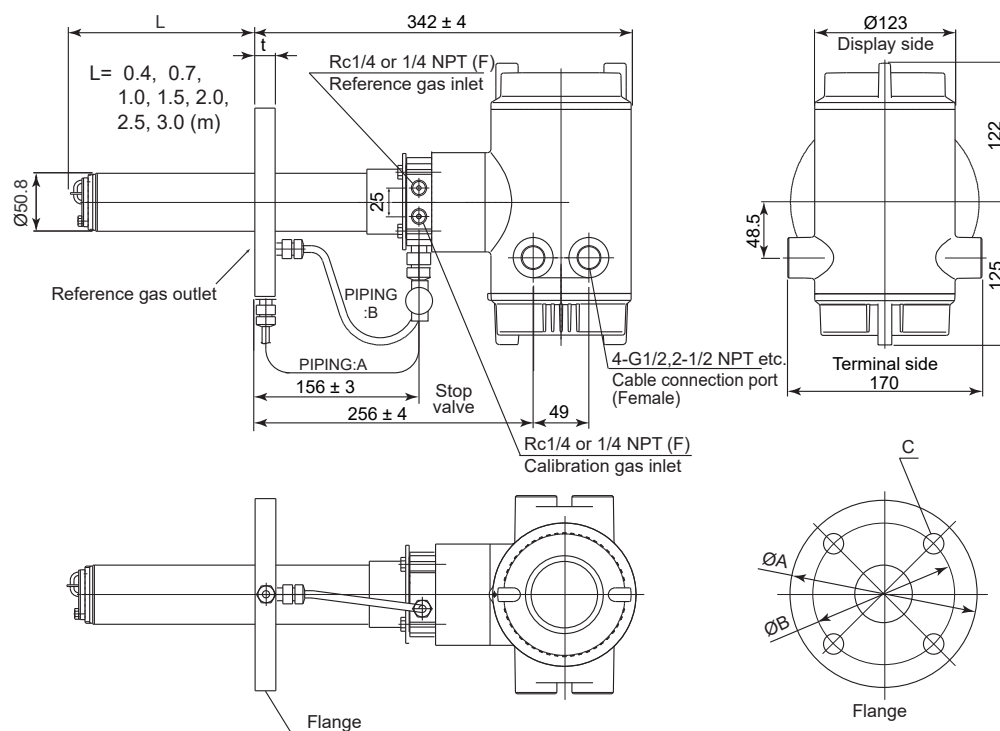

Flange	A	B	C	t	PIPING
ANSI Class 150 2 RF	152.4	120.6	4 - Ø19	19	A
ANSI Class 150 3 RF	190.5	152.4	4 - Ø19	24	B
ANSI Class 150 4 RF	228.6	190.5	8 - Ø19	24	B
DIN PN10 DN50 A	165	125	4 - Ø18	18	A
DIN PN10 DN80 A	200	160	8 - Ø18	20	B
DIN PN10 DN100 A	220	180	8 - Ø18	20	B
JIS 5K 65 FF	155	130	4 - Ø15	14	A
JIS 10K 65 FF	175	140	4 - Ø19	18	A
JIS 10K 80 FF	185	150	8 - Ø19	18	B
JIS 10K 100 FF	210	175	8 - Ø19	18	B
JPI Class 150 4 RF	229	190.5	8 - Ø19	24	B
JPI Class 150 3 RF	190	152.4	4 - Ø19	24	B
Westinghouse	155	127	4 - Ø11.5	14	A

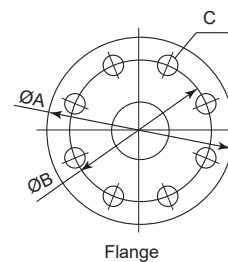

- With sun shield hood (option code /H)

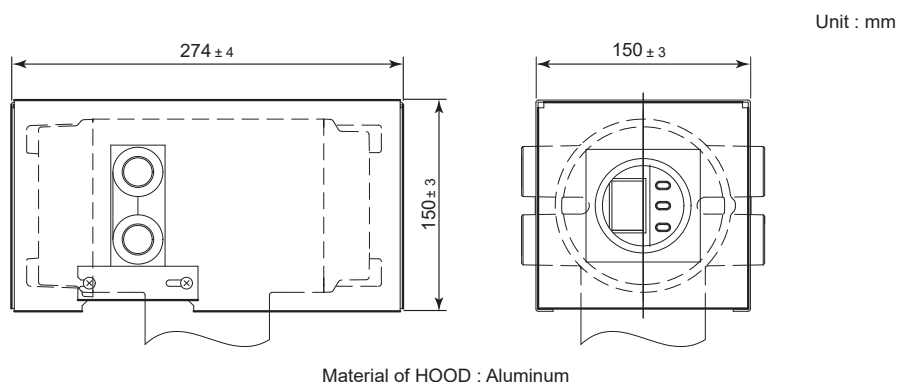

- Check Valve (option code /CV), Stop valve (option code /SV) -specified Calibration gas inlet

Unit: mm

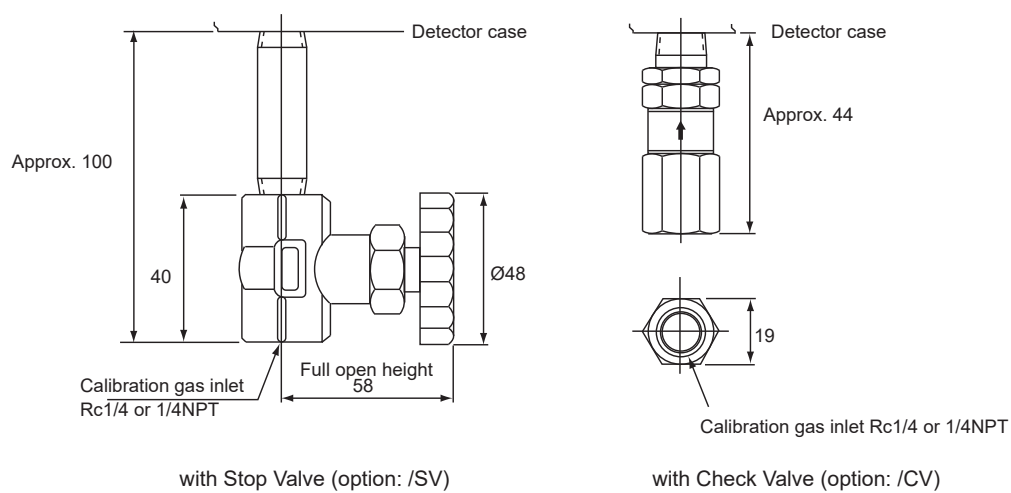

4. ZO21P High Temperature Probe Adapter for Oxygen Analyzer

Unit: mm

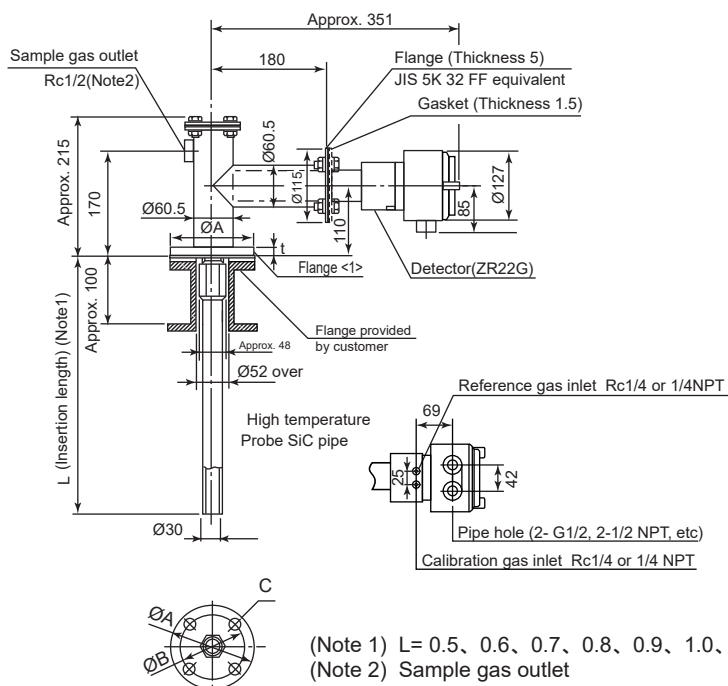

<1> Flange	A	B	C	t
JIS 5K 50 FF	130	105	4 - Ø15	14
JIS 10K 65 FF	175	140	4 - Ø18	18
JIS 10K 80 FF	185	150	8 - Ø19	18
JIS 10K 100 FF	210	175	8 - Ø19	18
ANSI Class 150 4 RF	228.6	190.5	8 - Ø19	24
ANSI Class 150 3 RF	190.5	152.4	4 - Ø19	24
ANSI Class 150 2 1/2 RF	177.8	139.7	4 - Ø19	24
JPI Class 150 3 RF	229	190.5	8 - Ø19	24
JPI Class 150 4 RF	190	152.4	4 - Ø19	24
DIN PN10 DN50 A	165	125	4 - Ø18	18

5. E7046EC/E7046EN Ejector Assembly for High Temperature Probe of Oxygen Analyzer

Unit : mm

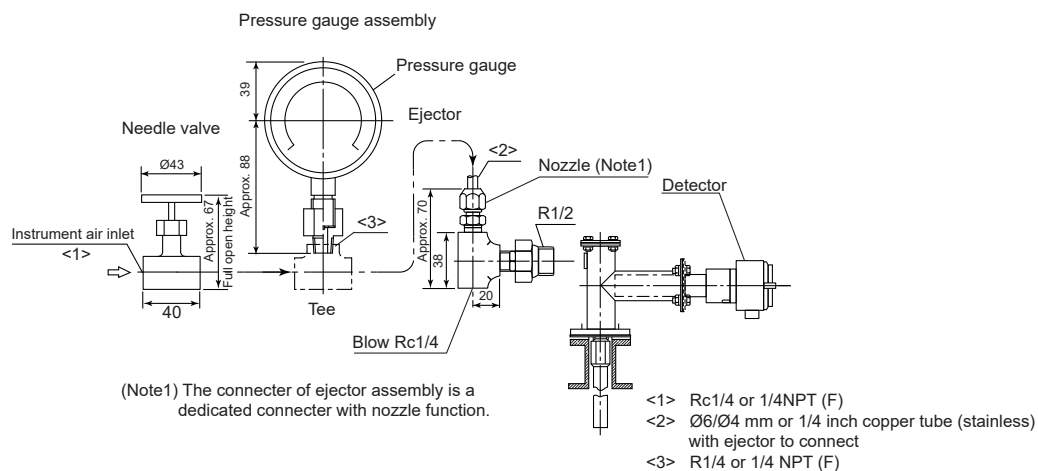

6. ZO21R Probe Protector for Oxygen Analyzer

Unit: mm

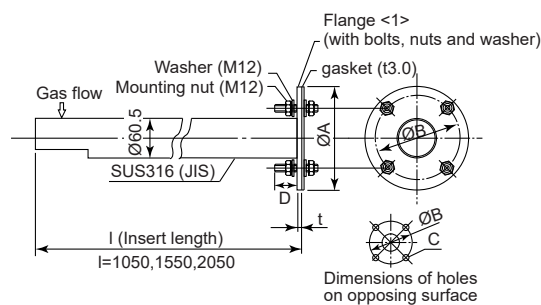

Flange<1>	A	B	C	t	D
JIS 5K 65 FF	155	130	4 - Ø15	5	40
ANSI Class 150 4 FF	228.6	190.5	8 - Ø19	12	50

7. K9471UA Dust Filter for Oxygen Analyzer

Unit : mm

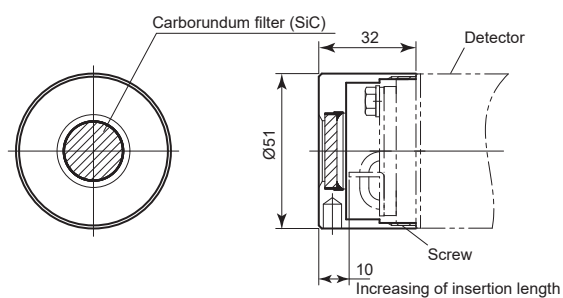

8. K9471UC Dust Guard Protector for Oxygen Analyzer

Unit : mm

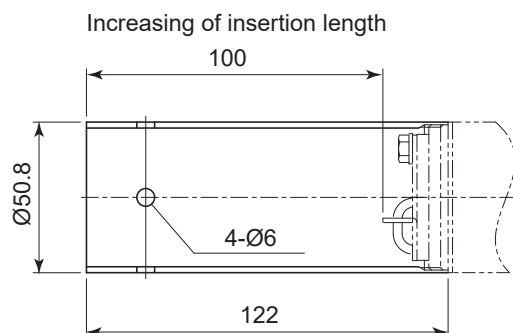

9. ZH21B Dust Protector for Humidity Analyzer

Unit: mm

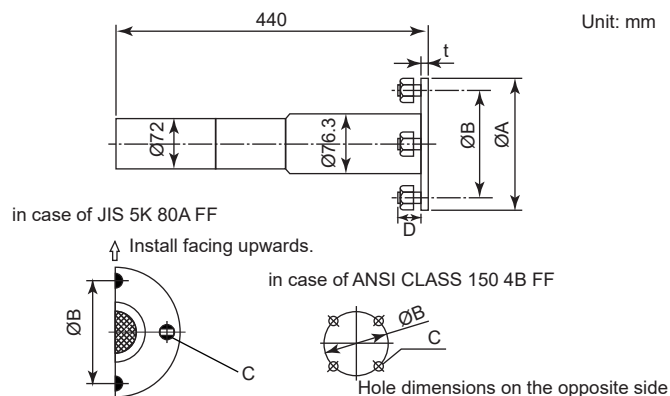

Flange	A	B	C	t	D
JIS 5K 80 FF	180	145	4-Ø19	14	40
ANSI Class 150 4B FF	228.5	190.5	8-Ø19	12	50

10. ZO21S Standard Gas Unit

Unit : mm

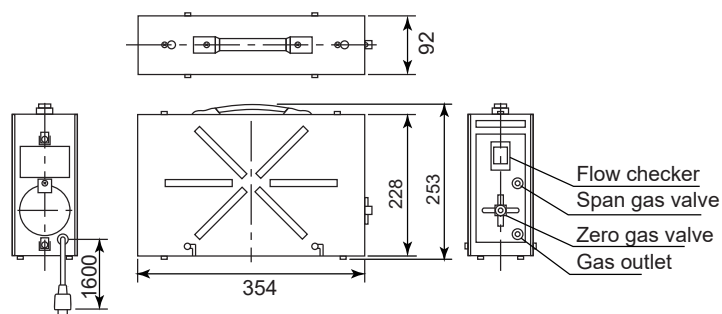

Zero gas cylinder (6 cylinder): E7050BA

11. ZA8F Flow Setting Unit for manual calibration

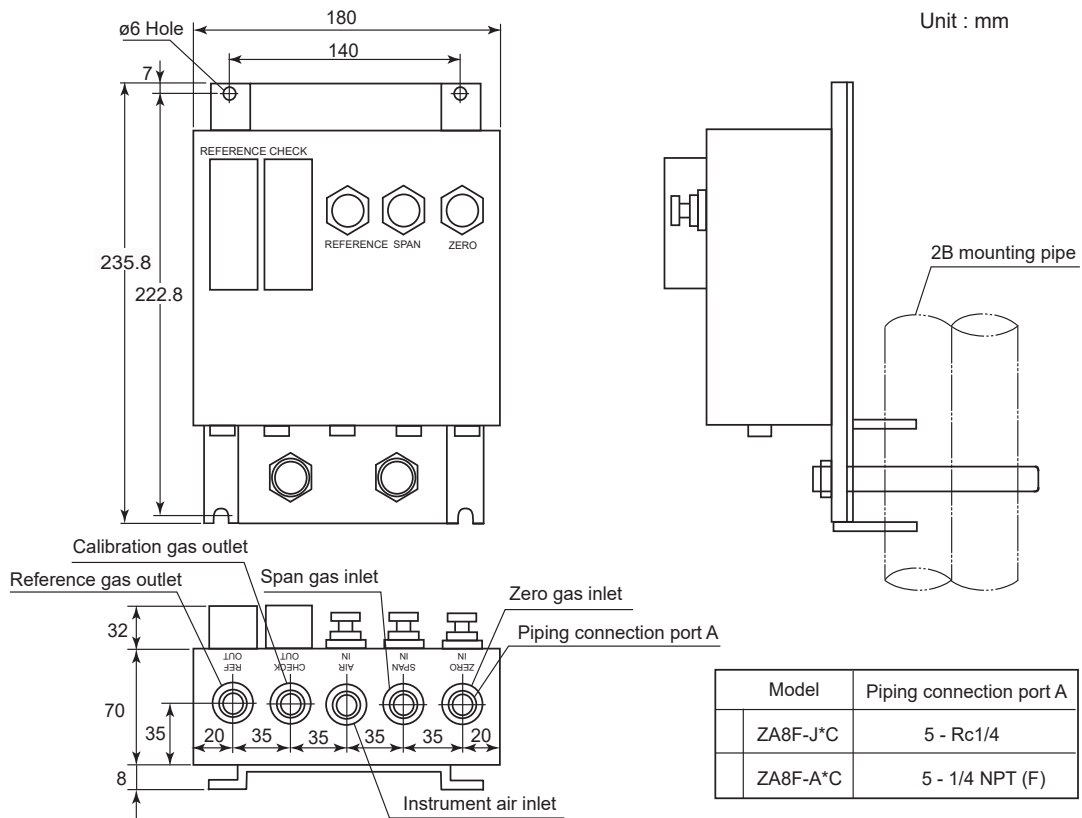

Weight : Approx. 2.3 kg

PIPING INSIDE THE FLOW SETTING UNIT

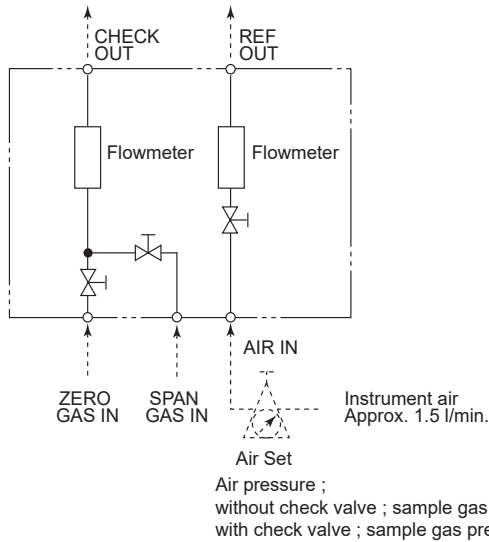

12. ZR40H Automatic Calibration Unit for ZR802G

2B pipe mounting example

Unit: mm

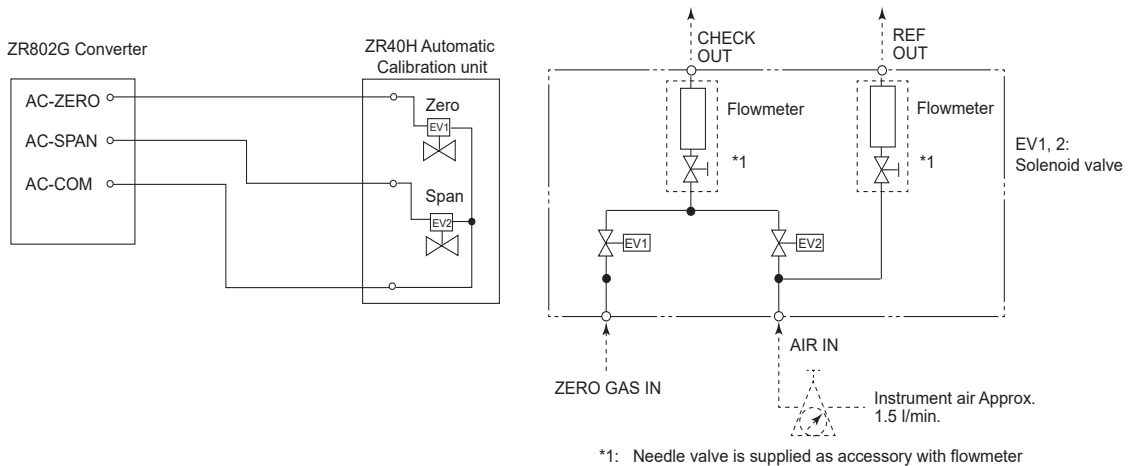
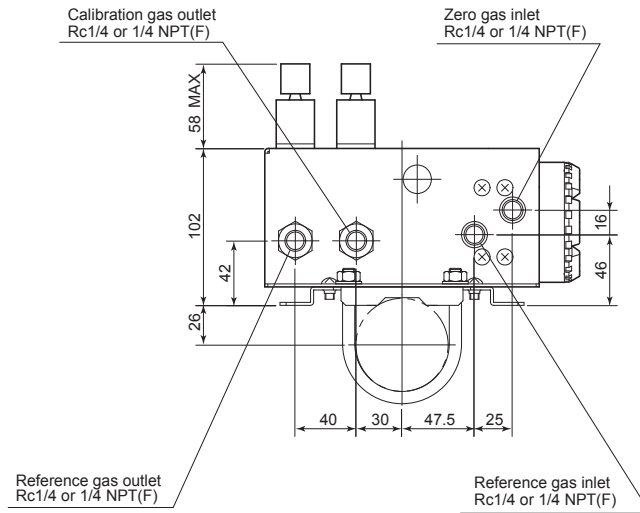
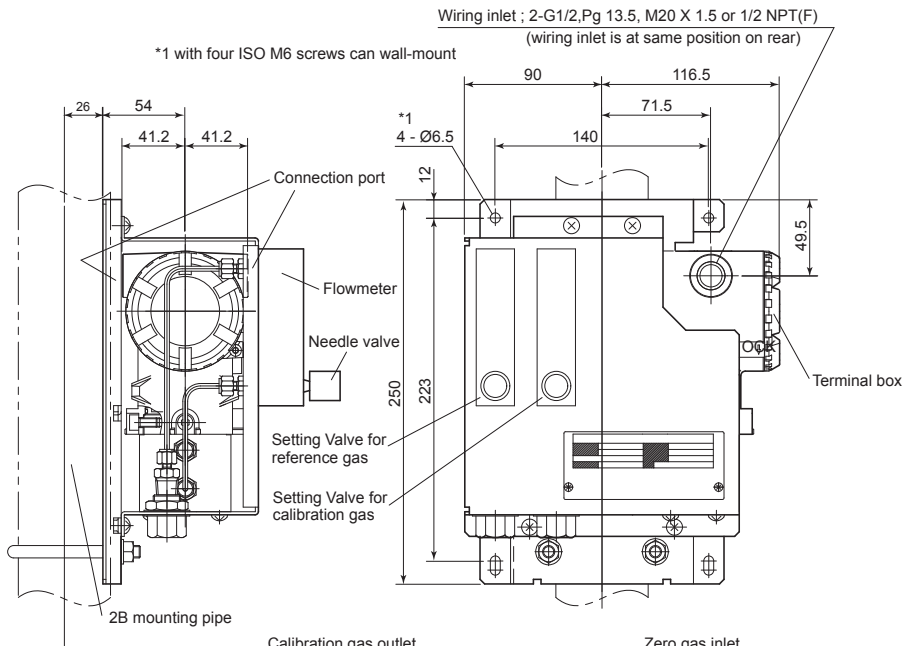

13. ZR20H Automatic Calibration Unit for ZR202G

Horizontal mounting on the ZR202G (-A)

Unit: mm

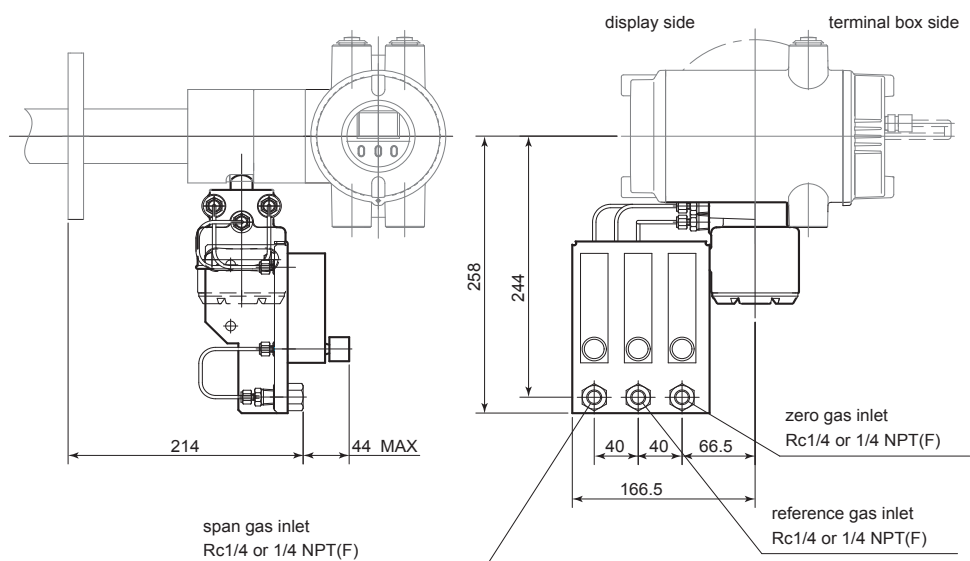

Vertical mounting on the ZR202G (-B)

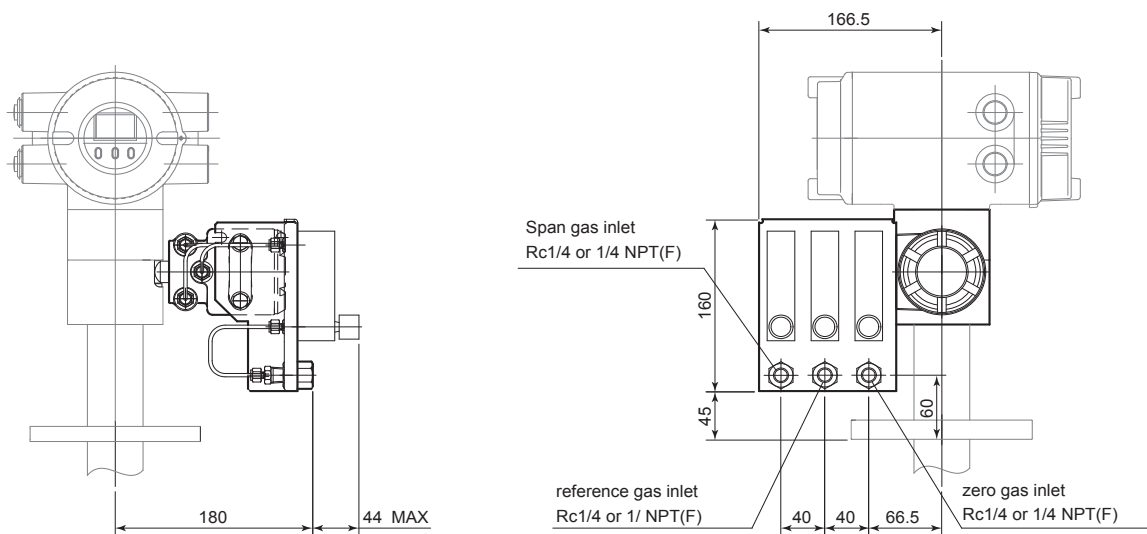

14. L9852CB/G7016XH Stop Valve for Calibration gas line

Unit : mm

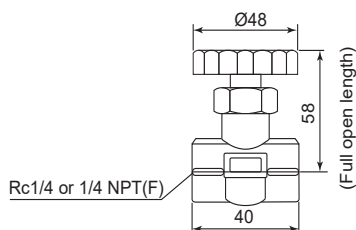

15. K9292DN/K9292DS Check Valve for Calibration gas line

Unit: mm

K9292DN : Rc1/4(A), R1/4(B)
 K9292DS : 1/4 NPT(A), 1/4 NPT(Male)(B)

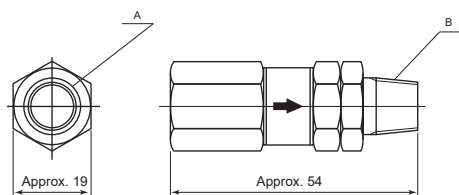

16. G7003XF/K9473XK, G7004XF/K9473XG Air Set

Unit: mm

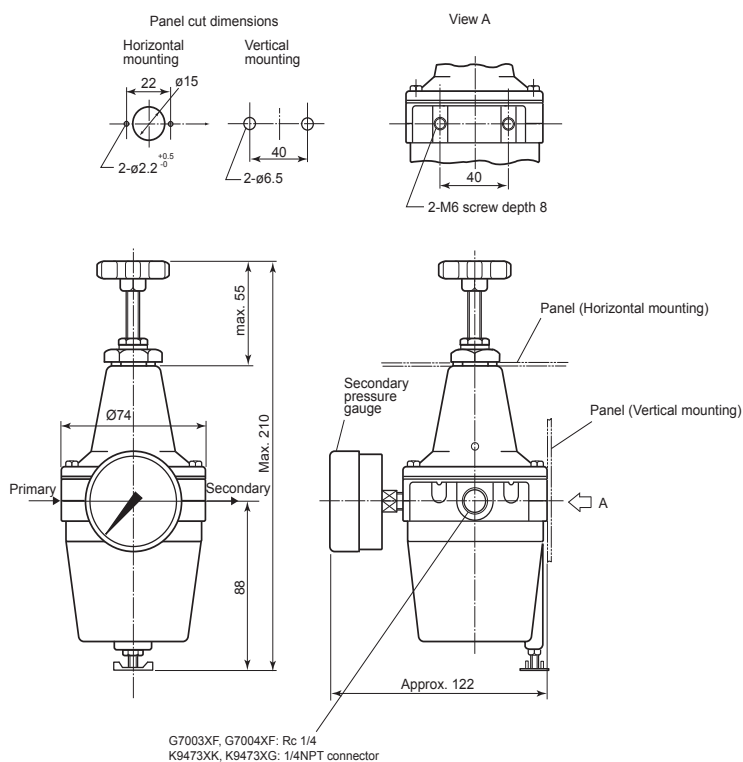

17. G7001ZC Zero gas Cylinder

Unit: mm

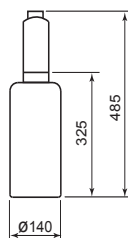

(Note) Export of such high pressure filled gas cylinders to most countries is prohibited or restricted.

18. G7013XF/G7014XF Pressure Regulator for Gas Cylinder

Unit: mm

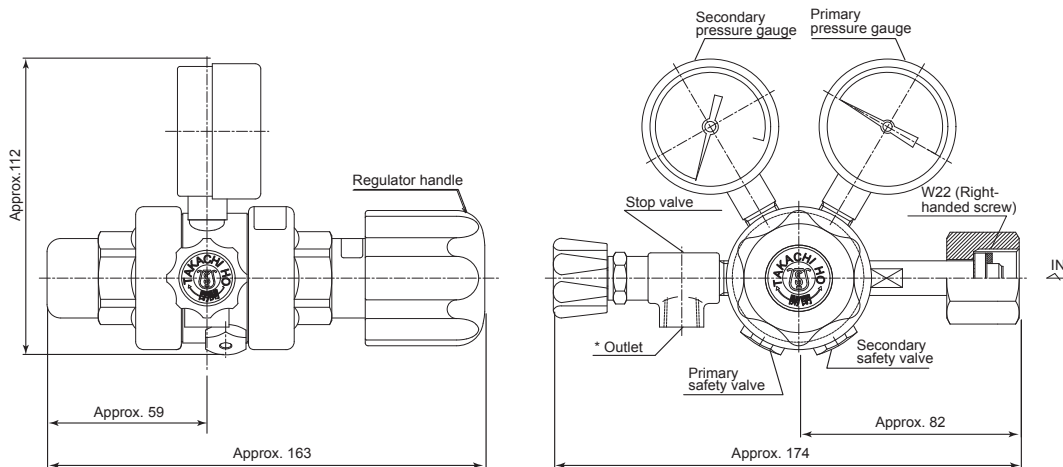

Part No.	* Outlet
G7013XF	Rc1/4
G7014XF	1/4 NPT (F)

19. E7044KF Case Assembly for Calibration-gas Cylinder

Unit : mm

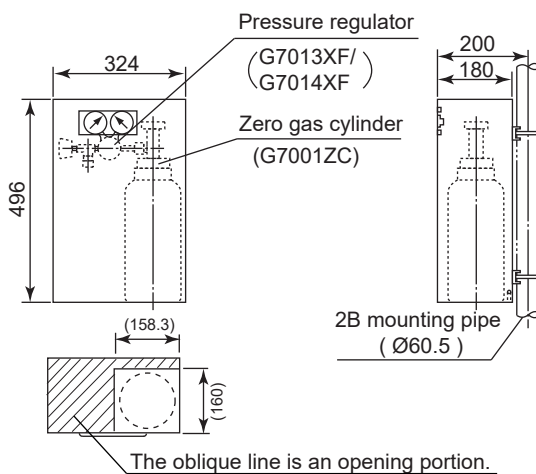

(Note)The zero gas cylinder and the regulator valve are not included in the E7044KF (case assembly)

20. ZR22A Heater Assembly for ZR22G

Unit : mm

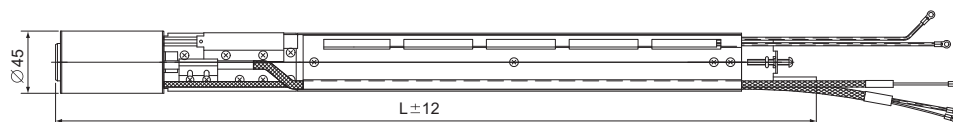

L: length

Model & Code	L	Weight (kg)
ZR22A-015	302	Approx. 0.5
ZR22A-040	552	Approx. 0.8
ZR22A-070	852	Approx. 1.2
ZR22A-100	1152	Approx. 1.6
ZR22A-150	1652	Approx. 2.2
ZR22A-200	2152	Approx. 2.8
ZR22A-250	2652	Approx. 3.4
ZR22A-300	3152	Approx. 4.0

ZR22A-□□□-A (Jig for change)

Part No. K9470BX

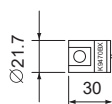

21. ZR202A Heat Assembly for ZR202G

Unit : mm

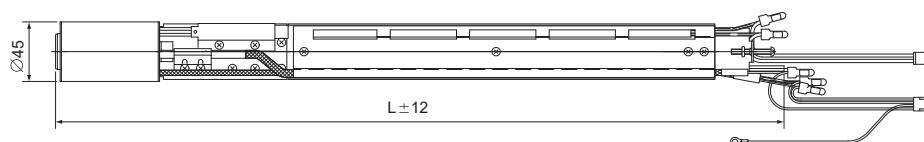

L: length

Model & Code	L	Weight (kg)
ZR202A-040	552	Approx. 0.8
ZR202A-070	852	Approx. 1.2
ZR202A-100	1152	Approx. 1.6
ZR202A-150	1652	Approx. 2.2
ZR202A-200	2152	Approx. 2.8
ZR202A-250	2652	Approx. 3.4
ZR202A-300	3152	Approx. 4.0

ZR202A-□□□-A (Jig for change)

Part No. K9470BX

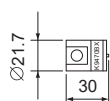

WIRING CONNECTIONS

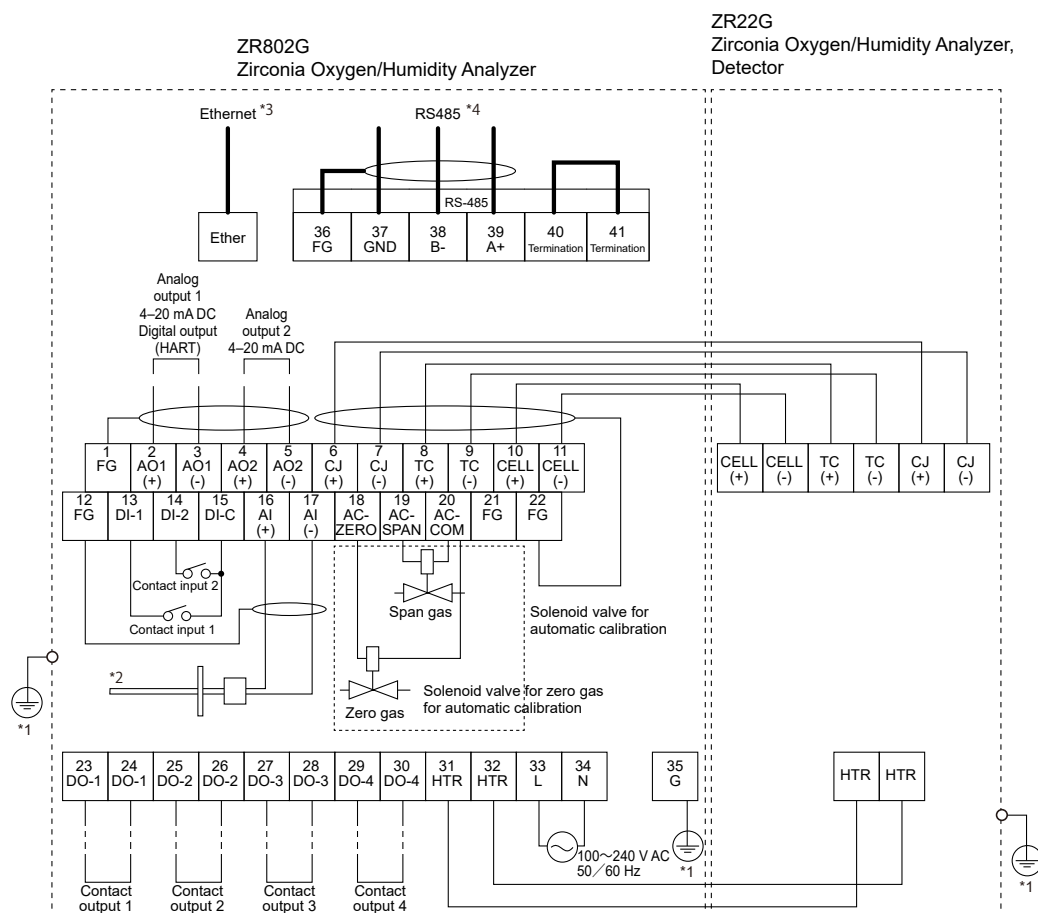

*1: The ground wiring of the converter should be connected to either the protective ground terminal in the equipment or the ground terminal of the converter case.

Ground to earth, ground resistance: 100 Ω or less.

*2: Option (Temperature or Pressure transmitter provide by user) for humidity measurement.

*3: Suffix Code "-E"

*4: Suffix Code "-M"

Model ZR202G Integrated type Zirconia Oxygen Analyzer

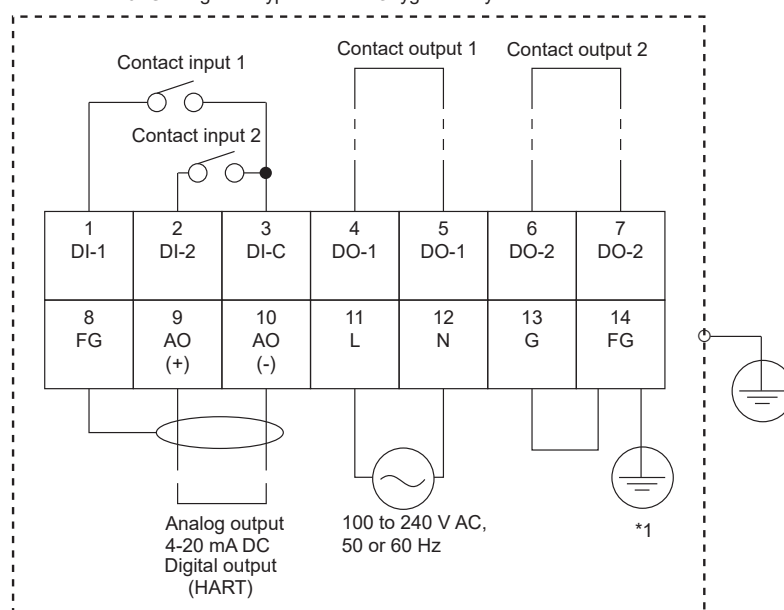

The protective grounding for the analyzer shall be connected either the protective ground terminal in the equipment or the ground terminal on the case.

Standard regarding grounding: Ground to earth, ground resistance: 100Ω or less.

Inquiry Sheet for Models ZR22G, ZR802G, and ZR202G Direct In Situ Zirconia Oxygen Analyzers and High Temperature Humidity Analyzers

Please place checkmarks in the appropriate boxes and fill in the necessary information in the blanks.

1 General information
 Type of analyzer: Oxygen Analyzer High Temperature Humidity Analyzer
 Customer Separate type Integrated type
 Destination of delivery Object: indication record control alarm
 Plant name Fuel: gas oil coal
 Measurement points Power requirements _____ VAC _____ Hz

2 Process conditions

2.1 Measurement gas components

2.2 Oxygen concentration Nor. _____ Min. _____ Max. _____ vol%O₂ _____

Moisture contents Nor. _____ Min. _____ Max. _____ kg/kg _____ vol%H₂O _____

2.3 Temperature Nor. _____ Min. _____ Max. _____ _____

2.4 Pressure Nor. _____ Min. _____ Max. _____ kPa _____

2.5 Gas flow Nor. _____ Min. _____ Max. _____ m/sec _____

2.6 Dust type, Size Nor. _____ Min. _____ mm quantity _____ g/Nm³ _____

2.7 Corrosive gas No gas Gas quantity _____ ppm _____
 _____ quantity _____ ppm _____

2.8 Combustible gas No gas Gas quantity _____ ppm _____
 _____ quantity _____ ppm _____

2.9 Others _____

3 Installation site conditions

3.1 Ambient temperature 1. Around Probe temp. from _____ to _____ °C, 2. Around Converter temp. from _____ to _____ °C

3.2 Vibration No vibration Vibration _____

3.3 1 Probe installation location Vibration Stack Others _____
 2 Probe position Horizontal Vertical Others _____
 Indoor Outdoor Covered

3 Probe insertion length (m) (Note) 0.4 0.7 1.0 1.5 2.0 2.5 3.0 3.6 4.2 4.8 5.4

4 Flange DIN _____ ANSI _____ Others _____

3.4 Instrument air supply Cannot be used. Can be used. _____ kPa

3.5 Converter location Indoor Outdoor Covered (under roof)

3.6 Cable length between probe and converter _____ meters

3.7 Calibration method Manual Automatic

(Note) 3.6m or more is available only in the U.S.

4 Quotation data

Quotation		Quantity	Description
Probe	ZR22G General-use Probe		Refer to the Probe Configuration for probe selection.
	ZO21P-H High Temperature Probe Adapter		
	E7046EC /E7046EN Ejector Assembly for high temperature use.		
	Options (for general use)		
	ZH21B Dust Protector for High Temperature Humidity Analyzer.		
	ZO21R Probe Protector for Oxygen Analyzer		
	K9471UA Filter for Oxygen Analyzer		
ZR802G Separate type Zirconia Oxygen/Humidity Analyzer, Converter			
ZR202G Integrated type Zirconia Oxygen /High Temperature Humidity Analyzer			
ZO21S Standard Gas Unit			Select any one of ZO21S, ZA8F, ZR40H, ZR20H.
ZA8F Flow Setting Unit			
ZR40H, ZR20H Automatic Calibration Unit			
L9852CB /G7016XH Stop Valve			Not required if probe options are specified.
K9292DN /K9292DS Check Valve (*1)			
G7003XF/K9473XK, G7004XF/K9473XG Air Set			
G7001ZC Zero Gas Cylinder (*2)			
G7013XF /G7014XF Pressure Regulator			
ZR22A, ZR202A Heater Assembly (Spare Parts)			

*1 When Automatic Calibration of "-A" or "-B" code is specified, ZR20H is installed in ZR202G.

*2 Export of such high pressure filled gas cylinders to most countries is prohibited or restricted.